

Piezoelectric Ceramics (PIEZOTITE®) Sensors



Preface

Recently, with the remarkable advance of electronics technology, various new products have come into existence. Until this time, the effect of electronics was seen most clearly in television, radio and other communications equipment, but as semiconductor technology, and computer technology advance, the range of electronics' effect on our lives has increased dramatically. In particular, sensor technology and the greater intelligent functions of today's microcomputers have served as a basis for the trend toward combining electronics and mechanics into what is called mechatronics.

It is not merely the equipment itself, however, that has made all this possible. Within the equipment are highly sophisticated components with unique functions which can translate electrical to mechanical energy and mechanical to electrical energy and which play a large role in today's equipment modernization and advance. These are piezoelectric components. This catalog briefly introduces the basics of piezoelectric ceramics, Murata's piezoelectric ceramics materials, piezoelectric transducers and other products.

Please insure the component is thoroughly evaluated in your application circuit.

In case that the component is not mentioned in our catalog, please contact your Murata representative for details.

for EU RoHS Compliant

- All the products in this catalog comply with EU RoHS.
- EU RoHS is "the European Directive 2002/95/EC on the Restriction of the Use of Certain Hazardous Substances in Electrical and Electronic Equipment".
- For more details, please refer to our website 'Murata's Approach for EU RoHS' (<http://www.murata.com/info/rohs.html>).

CONTENTS

PIEZOTITE®, CERAFIL®, CERALOCK® and GYROSTAR® in this catalog are the trademarks of Murata Manufacturing Co., Ltd.

1	Introduction	2
2	Characteristics of Piezoelectric Ceramics	3
	1. Resonant Frequency and Vibration Mode	3
	2. Piezoelectric Material Constant Symbols	6
	1 Frequency Constant N	6
	2 Piezoelectric Constants d and g	6
	3 Electromechanical Coupling Coefficient k	6
	4 Mechanical Qm	6
	5 Young's Modulus Y ^E	7
	6 Poisson's Ratio σ ^E	7
	7 Density ρ	7
	8 Relative Dielectric Constant $\frac{\epsilon^T}{\epsilon_0}$	7
	9 Curie Temperature T _c	7
	10 Coercive Field E _c	7
3	Murata's Piezoelectric Ceramics Materials	8
	1. Characteristics of Typical Materials	8
	2. Features of Piezoelectric Ceramics Materials	9
	3. Temperature Characteristics and Aging	9
4	Murata's Piezoelectric Ceramics (PIEZOTITE®)	10
	1. Shapes / Part Numbering	10
	2. Standard Models and Specifications	10
	3. Notice	10
5	Piezoelectric Ceramics (PIEZOTITE®) Sensors	11
	Ultrasonic Sensors	12
	Shock Sensors	20

1 Introduction

2 Characteristics of Piezoelectric Ceramics

3 Murata's Piezoelectric Ceramics Materials

4 Murata's Piezoelectric Ceramics (PIEZOTITE®)

5 Piezoelectric Ceramics (PIEZOTITE®) Sensors

1 Introduction

1. What are Piezoelectric Ceramics?

Piezoelectric ceramics are known for what are called the piezoelectric and reverse piezoelectric effects. The piezoelectric effect causes a crystal to produce an electrical potential when it is subjected to mechanical vibration. In contrast, the reverse piezoelectric effect causes the crystal to produce vibration when it is placed in an electric field. Of piezoelectric materials, Rochelle salt and quartz have long been known as single-crystal piezoelectric substances. However, these substances have had a relatively limited application range chiefly because of the poor crystal stability of Rochelle salt and the limited degree of freedom in the characteristics of quartz. Later, barium titanate (BaTiO_3), a piezoelectric ceramic, was introduced for applications in ultrasonic transducers, mainly for fish finders. More recently, a lead titanate, lead zirconate system ($\text{PbTiO}_3\text{-PbZrO}_3$) appeared, which has electromechanical transformation efficiency and stability (including temperature

characteristics) far superior to existing substances. It has dramatically broadened the application range of piezoelectric ceramics. When compared with other piezoelectric substances, both BaTiO_3 and $\text{PbTiO}_3\text{-PbZrO}_3$ have the following advantages:

■ Advantages

- ① High electromechanical transformation efficiency
- ② High machinability
- ③ A broad range of characteristics can be achieved with different material compositions (high degree of freedom in characteristics design).
- ④ High stability
- ⑤ Suitable for mass production, and economical

Murata, as a forerunner in the piezoelectric ceramic industry, offers an extensive range of products with piezoelectric applications.

2. Properties of Piezoelectric Ceramics

Piezoelectric ceramics are a type of multi-crystal dielectric with a high dielectric constant and are formed by two processes: first, high temperature firing. After firing, they have the characteristic crystal structure shown in Fig. 1 (a) but do not yet exhibit the piezoelectric property because the electrical dipoles within the crystals are oriented at random and the overall moment of the dipoles is canceled out. To make ceramics piezoelectric they must be polarized. A DC electric field of several kV/mm is applied to the piece of ceramic to align the internal electrical dipoles in a single orientation (see Fig. 1 (b)). Due to the strong dielectric property of the ceramic, the dipole moment remains unchanged after the electric field is removed, and the ceramic thus exhibits a strong piezoelectric property (see Fig. 1 (c)). When an AC signal is applied to a piezoelectric ceramics in a frequency matching the specific elastic frequency of the ceramics (which depends on the shape of the material), the ceramic exhibits resonance. Since the ceramic has a very high electromechanical transforming efficiency at the point of resonance, many applications

use this resonance point. Also piezoelectric ceramics when molded in certain shapes have more than one point of resonance depending on vibration mode. In such a case, the vibration mode most suited for the application is selected.

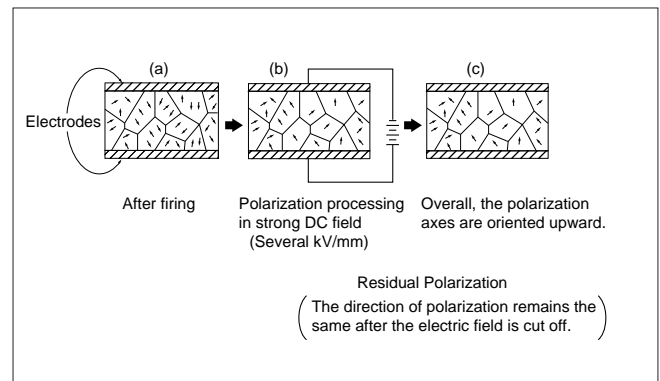

Fig. 1 Polarization Processing of Piezoelectric Ceramics

3. Application of Piezoelectric Ceramics

Product applications for piezoelectric ceramics include the following categories:
 Murata has and is continuing to direct extensive research development efforts to the entire range of applications of piezoelectric ceramics listed in the right side. It is expected that the applications of piezoelectric ceramics will continue to extend into a broader range of industries as new piezoelectric materials are created.
 This application manual concentrates on applications with mechanical power sources and sensors which are now finding broader applications.

■ Piezoelectric Applications

- ① Mechanical power sources (electrical-to-mechanical transducers):
Piezoelectric actuators, piezoelectric fans, ultrasonic cleaners, etc.
- ② Sensors (mechanical-to-electrical transducers):
Ultrasonic sensors, knocking sensors, shock sensors, acceleration sensors, etc.
- ③ Electronic circuit components (transducers):
Ceramic filters, ceramic resonators, surface acoustic wave filters, etc.

2 Characteristics of Piezoelectric Ceramics

For using piezoelectric ceramics, it is important to first have an adequate knowledge of the properties of different piezoelectric materials before choosing a suitable type for

a specific application. The following sections describe the major characteristics which need to be evaluated to determine the properties of piezoelectric ceramic materials.

1. Resonant Frequency and Vibration Mode

If an AC voltage of varying frequency is applied to a piezoelectric ceramics of a certain shape, it can be seen that there is a specific frequency at which the ceramic produces a very strong vibration. This frequency is called the resonant frequency, f_r , and depends on the ceramic's specific elastic vibration (resonance) frequency, which is a function of the shape of the material. Piezoelectric ceramics have various vibration modes (resonant modes) which depend on their shape, orientation of polarization, and the direction of the electric field. Each of these vibration modes have unique resonant frequencies and piezoelectric characteristics.

Fig. 2 shows typical vibration modes in relation to the shapes of ceramic materials, the resonant frequency in each vibration mode, and the material constant symbols. In Fig. 2, the piezoelectric material constant symbols have the following meanings:

- N** : Frequency Constant (described in Section 1).
- d** : Piezoelectric Distortion Constant (described in Section 2).
- g** : Voltage Output Coefficient (described in Section 2).
- k** : Electromechanical Coupling Coefficient (described in Section 3).
- Y^E** : Young's Modulus (described in Section 5).
- ϵ^T** : Dielectric Constant (described in Section 8).

Vibration Mode	Shape / Vibration Mode	Resonant Frequency (f_r)	Material Constant Symbol					
			k	d	g	Y^E	ϵ^T	N
Radial Mode	 <p>P: Direction of polarization E: Direction of electric field Thin disk with radial vibration mode. Polarization is oriented along the thickness of the disk.</p>	$\frac{N_p}{d}$	k_p	d_{31}	g_{31}	Y_{11}^E	ϵ_{33}^T	N_p
Length Mode	 <p>Thin rectangular plate, with the direction of vibration orthogonal to the polarization axis and with a single point of resonance.</p>	$\frac{N_{31}}{l}$	k_{31}	d_{31}	g_{31}	Y_{11}^E	ϵ_{33}^T	N_{31}
Longitudinal Mode	 <p>Square and cylindrical columns. Vibration is oriented along the direction of polarization. Only a single point of resonance.</p>	$\frac{N_{33}}{l}$	k_{33}	d_{33}	g_{33}	Y_{33}^E	ϵ_{33}^T	N_{33}
Thickness Mode	 <p>Disk and rectangular plates which are thin compared to their surface areas. They have multiple points of resonance in longitudinal vibration mode.</p>	$\frac{N_t}{t}$	k_t	d_{33}	g_{33}	Y_{33}^E	ϵ_{33}^T	N_t
Shear Mode	 <p>Disk or rectangular plates, with the electric field orthogonal to the direction of polarization, causing a shear vibration along the surface.</p>	$\frac{N_{15}}{t}$	k_{15}	d_{15}	g_{15}	Y_{44}^E	ϵ_{11}^T	N_{15}

Fig. 2 Typical Vibration Modes, Resonant Frequencies, and Material Constant Symbols of Piezoelectric Ceramics

2 Characteristics of Piezoelectric Ceramics

When a piezoelectric material is subjected to stress T , it produces polarization P which is a linear function of T : $P=dT$ (d : piezoelectric strain constant). This effect is called the normal piezoelectric effect. In contrast, when a piezoelectric substance has an electric field E applied across its electrodes, it produces distortion S which is a linear function of the electric field: $S=dE$. This effect is called the reverse piezoelectric effect. For an elastic material, the relationship of distortion S to the stress T is given by $S=s^E T$ (s^E : compliance); for a dielectric substance, the relationship of electrical displacement D with electric field strength E is given by $D=\epsilon E$. For a piezoelectric ceramic, these relationships are given by the following equations, both being associated with piezoelectric strain constants:

$$\left. \begin{aligned} S_i &= s_{ij}^E T_j + d_{mi} E_m \\ D_n &= d_{nj} T_j + \epsilon_{nm}^T E_m \end{aligned} \right\} \dots\dots (1)$$

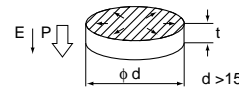
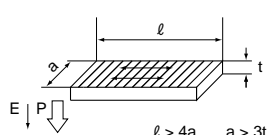
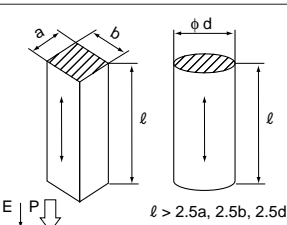
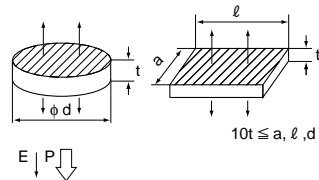
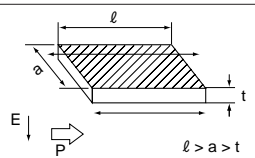
$(m, n = 1, 2, 3 ; i, j = 1, 2 \dots\dots, 6)$

These equations are called the basic piezoelectric equations (type d), where the electric field E and electrical displacement D are represented in vector magnitudes; whereas stress T and distortion S are given in symmetrical tensile magnitudes. When the symmetry of the crystals is taken into account, Eq. (1) is simplified because some constants in the equations are nullified and some other constants become equal to a third set of constants.

With piezoelectric ceramics, when the polarization axis is placed along the z (3) axis and two arbitrary orthogonal axes (which are also orthogonal to the z axis and assumed to be the x (1) and y (2) axis), the crystal structure of the ceramic can be represented in the same way as that of 6mm crystals, in which case the only independent non-zero coefficients are the following ten constants:

$$s_{11}^E \left(\frac{1}{Y_{11}^E} \right), s_{12}^E \left(\frac{1}{Y_{12}^E} \right), s_{13}^E \left(\frac{1}{Y_{13}^E} \right), s_{33}^E \left(\frac{1}{Y_{33}^E} \right), s_{44}^E \left(\frac{1}{Y_{44}^E} \right),$$

$$d_{31}, d_{33}, d_{15}, \epsilon_{11}^T, \epsilon_{33}^T,$$

For example, the basic piezoelectric equations for longitudinal vibration of a rectangular ceramic strip is given by the following equations:

$$\left. \begin{aligned} S_1 &= s_{11}^E T_1 + d_{31} E_3 \\ D_3 &= d_{31} T_1 + \epsilon_{33}^T E_3 \end{aligned} \right\} \dots\dots (2)$$

A piezoelectric ceramics can be represented by an equivalent circuit which is derived from the basic piezoelectric equations representing its vibration mode. The circuit is called Maison's equivalent circuit. More generally, the equivalent circuit, as shown in Fig. 3, may be used to represent a piezoelectric ceramic. In this equivalent circuit, the serial resonant frequency fs , and parallel resonant frequency fp are given by the following equations:

$$\left. \begin{aligned} fs &= \frac{1}{2\pi\sqrt{L_1 C_1}} \\ fp &= \frac{1}{2\pi\sqrt{L_1 \cdot \frac{C_1 C_0}{C_1 + C_0}}} \end{aligned} \right\} \dots\dots (3)$$

Constants fs and fp are necessary to determine the electro-mechanical coupling coefficient k .

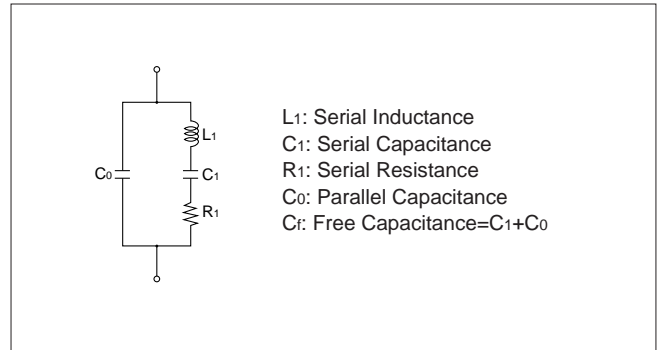

Fig. 3 Equivalent Circuit for Piezoelectric Ceramics

Strictly speaking, the resonant frequency can be defined in the following three ways:

- (1) Serial resonant frequency fs of the equivalent serial circuit for a piezoelectric ceramic transducer.
- (2) Lower resonance frequency fr , the lower of the two frequencies, where the cross-electrode admittance or impedance of the piezoelectric ceramic transducer is in the null phase.
- (3) Maximum admittance frequency fm where the cross-electrode admittance of the piezoelectric ceramic transducer is maximized (impedance minimized).

However, the differences between the three frequencies, fs , fr , and fm , is so small that it is negligible. In actual cases, therefore, when we measure frequency fm , it can be called resonant frequency fr . Also, the minimum admittance frequency fn may be called antiresonant frequency fa . The resonant frequency fr can be measured with either of the following two circuits: see Fig. 4 and 5, next page.

Characteristics of Piezoelectric Ceramics 2

■ Measuring Method Using Constant Voltage Circuit

The fr measuring circuit using a constant voltage source is shown in Fig. 4.

The oscillator Osc and input resistors R_1 and R_2 are used to apply a constant voltage signal to the piezoelectric ceramics transducer. The current passing through the transducer is measured across output resistor R_2 .

If the piezoelectric ceramics impedance is much greater than R_2 , the voltmeter reading is proportional to the piezoelectric ceramics' admittance. The frequency where the voltmeter reading is maximized is the resonant frequency fr , and the frequency where the reading is minimized is the antiresonant frequency fa .

Variable resistor R_v is used to determine the resonant resistance R_1 , which is needed to calculate the mechanical Q_m .

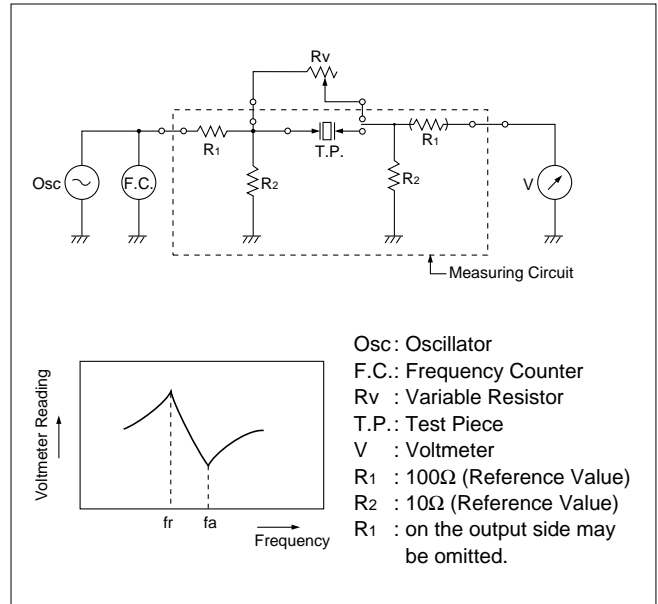

Fig. 4 Resonant Frequency Measuring Method Using Constant Voltage Circuit

■ Measuring Method Using Constant Current Circuit

The fr measuring circuit using a constant current source is shown in Fig. 5. Resistor R_3 regulates the current passing through the piezoelectric ceramics. If R_3 is much greater than the transducer's impedance, the voltmeter reading is proportional to the piezoelectric ceramics' impedance. The frequency where the voltmeter reading is minimized is the resonant frequency fr , and the frequency where the reading is maximized is the antiresonant frequency fa .

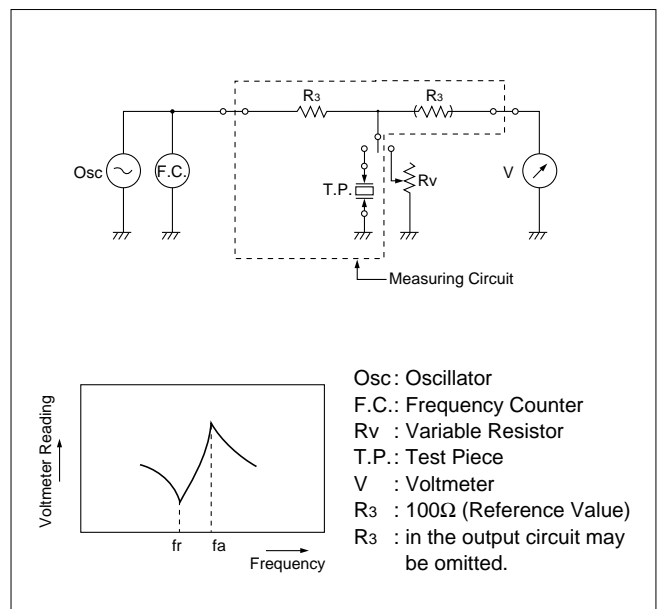

Fig. 5 Resonant Frequency Measuring Circuit Using Constant Current Circuit

2 Characteristics of Piezoelectric Ceramics

2. Piezoelectric Material Constant Symbols

1 Frequency Constant N

The velocity of sound that propagates through a piezoelectric ceramics has a specific value in each vibration mode when the resonance of other vibration modes is not in the vicinity. For a piezoelectric ceramics with a certain shape, the relationship of wavelength λ of a vibration with propagation length ℓ at the resonant point is given by equation (4). Because the sound velocity is constant, we obtain the following equations (5) and (6):

$$\frac{\lambda}{2} = \ell \dots\dots\dots (4)$$

$$v = fr \cdot \lambda \dots\dots\dots (5)$$

$$fr \cdot \ell = \frac{v}{2} = N \text{ (Hz} \cdot \text{m)} \dots\dots\dots (6)$$

where N is the frequency constant. The frequency constant depends on the vibration mode. The resonant frequency may also be determined by the equation, $fr = N/\ell$ as shown in Fig. 2.

2 Piezoelectric Constants d and g

① Piezoelectric Strain Coefficient d

Piezoelectric distortion constant is the distortion resulting from the application of an electric field of uniform strength with no stress. It is given by equation (7):

$$d = k \sqrt{\frac{\epsilon^T}{Y^E}} \text{ (m/V)} \dots\dots\dots (7)$$

where ϵ^T : Dielectric constant

Y^E : Young's modulus (N/m²)

k : Electromechanical coupling coefficient

$$d_{31} = k_{31} \sqrt{\frac{\epsilon_{33}^T}{Y_{11}^E}}, d_{33} = k_{33} \sqrt{\frac{\epsilon_{33}^T}{Y_{33}^E}}, d_{15} = k_{15} \sqrt{\frac{\epsilon_{11}^T}{Y_{44}^E}} \dots\dots\dots (8)$$

② Voltage Output Coefficient g

Voltage output coefficient refers to the field strength which results from a uniform stress applied under no electrical displacement. It is given by equation (9):

$$g = \frac{d}{\epsilon^T} \text{ (V} \cdot \text{m/N)} \dots\dots\dots (9)$$

$$g_{31} = \frac{d_{31}}{\epsilon_{33}^T}, g_{33} = \frac{d_{33}}{\epsilon_{33}^T}, g_{15} = \frac{d_{15}}{\epsilon_{11}^T} \dots\dots\dots (10)$$

Constants d and g depend on the vibration mode, and the constants in each vibration mode are given by the subscripted symbols shown in Fig. 2.

Displacements generated under an electric voltage or a voltage generated under force can be determined by constants d and g . For example, the displacement $\Delta \ell$ caused by voltage V applied across the electrodes in the lengthwise vibration mode is given by:

$$\frac{\Delta \ell}{\ell} = d_{31} \cdot \frac{V}{t} \dots\dots\dots (11)$$

Conversely, the voltage V caused by force F applied along the direction of vibration is given by:

$$V = g_{31} \cdot \frac{1}{a} F \dots\dots\dots (12)$$

3 Electro Mechanical Coupling Coefficient k

The electromechanical coupling coefficient is a constant representing the piezoelectric efficiency of a piezoelectric ceramic. More specifically, it represents the efficiency of converting electrical energy (applied across the electrodes of a piezoelectric ceramic) into mechanical energy, and it is defined as the root mean square of the energy accumulated within the crystal in a mechanical form. This accumulated energy reflects the total electrical input.

$$\text{Electromechanical Coupling Coefficient} = \sqrt{\frac{\text{Accumulated Mechanical Energy}}{\text{Supplied Electrical Energy}}}$$

The electromechanical coupling coefficient depends on the vibration mode, as shown in Fig. 2. It is determined by the following equations using the resonant frequency fr , anti-resonant frequency fa , and their difference $\Delta f = fa - fr$.

① Radial Vibration of Disk

$$kp^2 = \frac{(1 - \sigma^E) J_1 \{ \psi_1 (1 + \Delta f / fr) \} - \psi_1 (1 + \Delta f / fr) J_0 \{ \psi_1 (1 + \Delta f / fr) \}}{(1 + \sigma^E) J \{ \psi_1 (1 + \Delta f / fr) \}} \dots\dots\dots (13)$$

where J_0, J_1 : Type 1 vessel functions of the 0th and 1st dimensions

σ^E : Poisson's ratio

ψ_1 : Lowest dimension of positive root of $(1 - \sigma^E) J_1(\psi) = \psi J_0(\psi)$

If kp is relatively small, equation (13) may be approximated as follows:

$$kp^2 \approx 2.529 \cdot \frac{\Delta f}{fr} \dots\dots\dots (14)$$

② Lengthwise Vibration of Rectangular Plate

$$\frac{k_{31}^2}{1 - k_{31}^2} = -\frac{\pi}{2} \cdot \frac{fa}{fr} \cot \left(\frac{\pi}{2} \cdot \frac{fa}{fr} \right) \dots\dots\dots (15)$$

③ Longitudinal Vibration of Cylinder

$$k_{33}^2 = \frac{\pi}{2} \cdot \frac{fr}{fa} \cot \left(\frac{\pi}{2} \cdot \frac{fr}{fa} \right) \dots\dots\dots (16)$$

④ Vibration Along Thickness of Disk

$$k_t^2 = \frac{\pi}{2} \cdot \frac{fr}{fa} \cot \left(\frac{\pi}{2} \cdot \frac{fr}{fa} \right) \dots\dots\dots (17)$$

⑤ Shear Vibration of Rectangular Plate

$$k_{15}^2 = \frac{\pi}{2} \cdot \frac{fr}{fa} \cot \left(\frac{\pi}{2} \cdot \frac{fr}{fa} \right) \dots\dots\dots (18)$$

4 Mechanical Qm

Mechanical Q_m gives the "steepness" of resonance of a mechanical vibration at and around the resonant frequency. It is given by the following equation:

$$Qm = \frac{1}{2 \pi fr R_1 C_f} = \frac{1}{2 \pi fr R_1 Cf \left\{ 1 - \left(\frac{fr}{fa} \right)^2 \right\}} \dots\dots\dots (19)$$

where R_1 : Resonant resistance

C_f : Free capacitance across electrodes

Characteristics of Piezoelectric Ceramics 2

5 Young's Modulus Y^E

When stress T is applied to an elastic body within the proportional elastic range, strain S is given by the following formula:

$$S = s^E T$$

s^E is an elasticity constant (compliance), and Young's modulus is given as the inverse of compliance. For lengthwise vibrations shown in Fig. 3, for example, the Young's modulus is given by the following equation:

$$Y_{11}^E = (2\ell fr)^2 \cdot \rho = v^2 \cdot \rho \text{ (N/m}^2\text{)} \dots\dots\dots (20)$$

where ρ : Density (kg/m³)
 v : Sound velocity (m/s)

6 Poisson's Ratio σ^E

When a constant stress is applied to an elastic body within its proportional elastic range, Poisson's ratio is defined as follows:

$$\sigma^E = - \frac{\text{Distortion Rate Orthogonal to Stress}}{\text{Distortion Rate along Stress}}$$

7 Density ρ

Density can be determined from the volume and mass of any piezoelectric ceramics as follows:

$$\rho = \frac{m}{V} \text{ (kg / m}^3\text{)} \dots\dots\dots (21)$$

where m : Mass (kg)
 V : Volume (m³)

8 Relative Dielectric Constant $\frac{\epsilon^T}{\epsilon_0}$

Dielectric constant is an electrical displacement which results when a unity electric field is applied under no stress. It is given by the following formula:

$$D = \epsilon^T \cdot E$$

where E : Field strength
 D : Electrical displacement
 ϵ^T : Dielectric constant

Dielectric constant ϵ^T divided by the dielectric constant in a vacuum ϵ_0 ($=8.854 \times 10^{-12} \text{F/m}$) is called the relative dielectric constant. For the lengthwise vibration mode shown in Fig. 2, if the free capacitance across the electrodes at 1 kHz is assumed to be C_f , the relative dielectric constant for an electric field in the same direction of polarization is given by the equation:

$$\frac{\epsilon_{33}^T}{\epsilon_0} = \frac{C_f \cdot t}{\ell \cdot a \cdot \epsilon_0} \dots\dots\dots (22)$$

For the vibration along thickness shown in Fig. 2, if the free capacitance across the electrodes at 1 kHz is assumed to be C_f , the relative dielectric constant for an electric field orthogonal to the direction of polarization is given by this equation:

$$\frac{\epsilon_{11}^T}{\epsilon_0} = \frac{C_f \cdot t}{\ell \cdot a \cdot \epsilon_0} \dots\dots\dots (23)$$

9 Curie Temperature T_c

Curie temperature refers to the critical temperature at which crystals in the piezoelectric ceramics lose their spontaneous polarization and hence their piezoelectric property. It is defined as the temperature at which the dielectric constant is maximized when the temperature is increased.

10 Coercive Field E_c

Ferroelectric materials have a domain structure, as shown in Fig. 1. The dipole moment in each domain is oriented in the same direction and causes spontaneous polarization. If a varying electric field E is applied to it, the overall variation of polarization draws a hysteresis loop, as shown in Fig. 6. Once the material has an electric field applied to it, it does not return to the original domain structure when the electric field is removed, resulting in remanent polarization P_r . To cancel P_r , a certain strength of reverse electric field must be applied. The field strength E_c required to cancel the remanent polarization is called a coercive field.

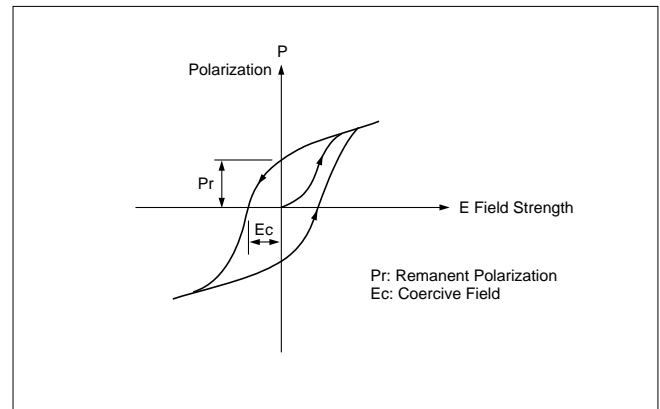

Fig. 6 Hysteresis Loop of a Ferroelectric Materials

3 Murata's Piezoelectric Ceramics Materials

1. Characteristics of Typical Materials

Table 1 shows the characteristics of typical Murata's piezoelectric ceramics materials.

Item	Symbol (Unit)	P- 3	P- 5C	P- 5E	P- 6C	P- 6E	P- 6F	P- 7	P- 7B
Relative Dielectric Constant	$\epsilon_{11}^T/\epsilon_0$	—	1230	1490	760	1260	1670	1930	3200
	$\epsilon_{33}^T/\epsilon_0$	1070	1550	1510	800	1380	1780	2100	4720
Loss Coefficient	$\tan \delta$ (%)	0.5	0.3	0.4	1.0	1.4	1.2	1.4	2.2
Electro-mechanical Coupling Factor	k_p [Radial] (%)	22	56	56	39	46	57	65	65
	k_{31} [Length] (%)	15	32	32	21	26	32	38	36
	k_{33} [Longitudinal] (%)	44	54	62	50	60	65	71	68
	k_t [Thickness] (%)	36	42	45	43	44	48	51	47
	k_{15} [Shear] (%)	—	50	60	47	53	61	66	57
Piezoelectric Constant	d_{31} (10^{-12}m/V)	-44	-131	-131	-3	-94	-148	-207	-303
	d_{33} (10^{-12}m/V)	133	225	271	135	235	311	410	603
	d_{15} (10^{-12}m/V)	—	294	400	196	309	431	550	592
	g_{31} ($10^{-3}\text{V}\cdot\text{m/N}$)	-5	-10	-10	-8	-8	-9	-11	-7
	g_{33} ($10^{-3}\text{V}\cdot\text{m/N}$)	14	16	20	19	19	20	22	14
	g_{15} ($10^{-3}\text{V}\cdot\text{m/N}$)	—	27	30	29	28	29	32	21
Frequency Constant	N_p [Radial] (Hz·m)	3140	1920	2250	2520	2410	2210	2050	1960
	N_{31} [Length] (Hz·m)	2270	1580	1610	1850	1730	1540	1430	1370
	N_{33} [Longitudinal] (Hz·m)	2210	1670	1550	1820	1670	1540	1400	1350
	N_t [Thickness] (Hz·m)	2590	2180	2060	2130	2110	2060	2000	1970
	N_{15} [Shear] (Hz·m)	—	1020	1010	1150	1080	1000	930	930
Mechanical Q	Q_m	720	2070	970	680	410	110	80	70
Elastic Constant	S_{11}^E ($10^{-12}\text{m}^2/\text{N}$)	8.7	12.6	12.4	9.4	11.1	13.4	15.8	16.7
	S_{12}^E ($10^{-12}\text{m}^2/\text{N}$)	-2.6	-4.7	-4.1	-3.0	-3.6	-4.8	-5.7	-5.9
	S_{13}^E ($10^{-12}\text{m}^2/\text{N}$)	-2.9	-5.3	-5.2	-3.0	-4.3	-5.4	-7.0	-7.5
	S_{33}^E ($10^{-12}\text{m}^2/\text{N}$)	9.6	12.8	14.3	10.3	12.7	14.5	18.1	18.8
	S_{44}^E ($10^{-12}\text{m}^2/\text{N}$)	—	31.6	34.0	25.6	30.0	34.2	40.6	38.8
	S_{66}^E ($10^{-12}\text{m}^2/\text{N}$)	22.7	34.6	33.0	24.8	29.3	36.5	43.0	45.4
	Y_{11}^E (10^{10}N/m^2)	11.5	8.0	8.1	10.7	9.0	7.5	6.3	6.7
Poisson's Ratio	σ^E	0.30	0.37	0.33	0.32	0.33	0.36	0.36	0.36
Density	ρ (10^3kg/m^3)	5.6	8.0	7.8	7.7	7.6	7.9	7.8	8.0
Temperature Coefficient	TK (fr) (ppm/°C)	—	324	115	10	35	38	59	336
	TK (Cf) (ppm/°C)	—	1500	3500	2500	3000	—	4500	13500
Curie Temperature	T_c (°C)	120	360	280	320	270	280	300	180
Linear Expansion Ratio	α ($10^{-6}/\text{°C}$)	5	2	4	2	3	4	2	2
Bending Strength	τ (10^6N/m^2)	113	101	113	125	116	103	99	85
Applications		Fish finders sonar	Ultrasonic cleaners Actuator for high power		Knock sensor	Sensor		Ultrasonic-sensor Pickup Actuator Acoustic-application	Actuator Acoustic-application

Note: This table shows typical values measured on standard test piece. Q_m , TK (fr) and TK (Cf) are measured for radial vibration mode.

Table 1 Characteristics of Murata's Typical Piezoelectric Ceramics

Murata's Piezoelectric Ceramics Materials 3

2. Features of Piezoelectric Ceramics Materials

Table 2 shows the features of piezoelectric ceramics materials. Murata's piezoelectric ceramics include two types: barium titanate (BaTiO_3) and lead zirconate titanate

($\text{PbTiO}_3\text{-PbZrO}_3$). Materials using lead zirconate titanate are available with different properties suitable for different applications.

Type	Type Number	Features
Barium Titanate	P-3	The major constituent of P-3 is barium titanate, with titanate additives to improve the characteristics at room temperature. While it has a lower electromechanical coupling coefficient and Curie temperature compared to Lead Zirconate Titanate, it is practical in underwater applications and has the advantage of economy. With these features, P-3 is best suited for use in fish finders or sonar.
Lead Zirconate Titanate	P-5E	Featuring a large electromechanical-coupling coefficient, mechanical Qm and minimal aging, P-5 is widely used for ultrasonic cleaners, high-power ultrasonic transducers, and other acoustic power applications.
	P-6C	Features superior temperature characteristics of resonant frequency and minimal aging. P-6 is often used in ceramic filters, ceramic resonators requiring high stability.
	P-7	Features large electromechanical coupling coefficient, constant d and small mechanical Qm. P-7 has applications in piezoelectric buzzers, ultrasonic sensors, and other applications requiring non-resonance or broad bandwidth.

Table 2 Features of Piezoelectric Ceramics

3. Temperature Characteristics and Aging

Fig. 7 shows examples of temperature characteristics of various materials.

Fig. 8 shows examples of aging characteristics of various materials. These examples show small aging characteristics.

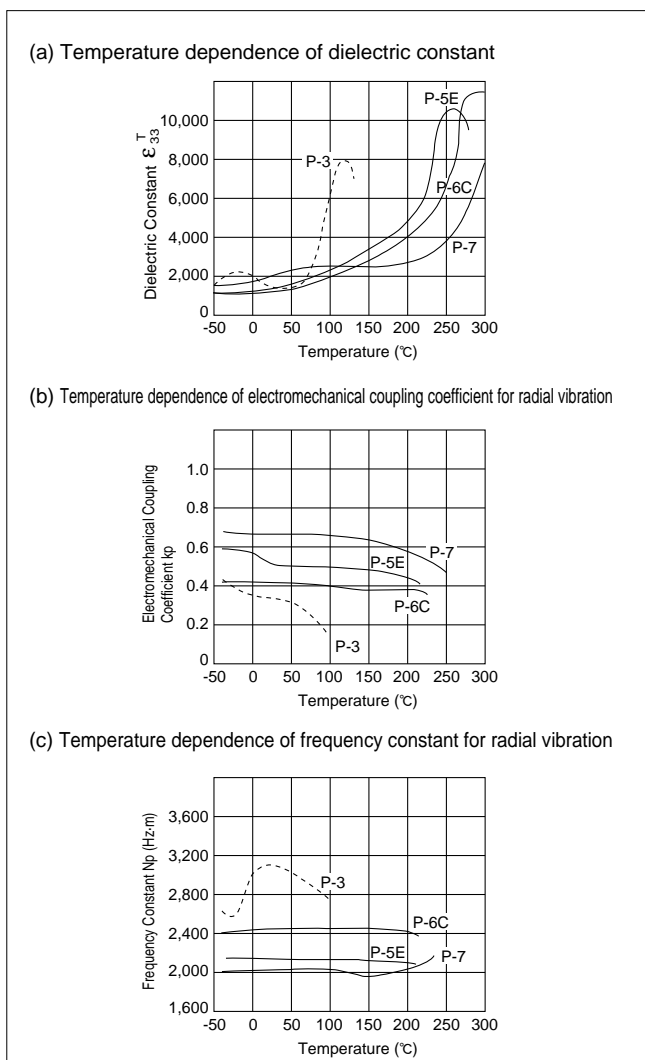

Fig. 7 Temperature Characteristics of Various Materials

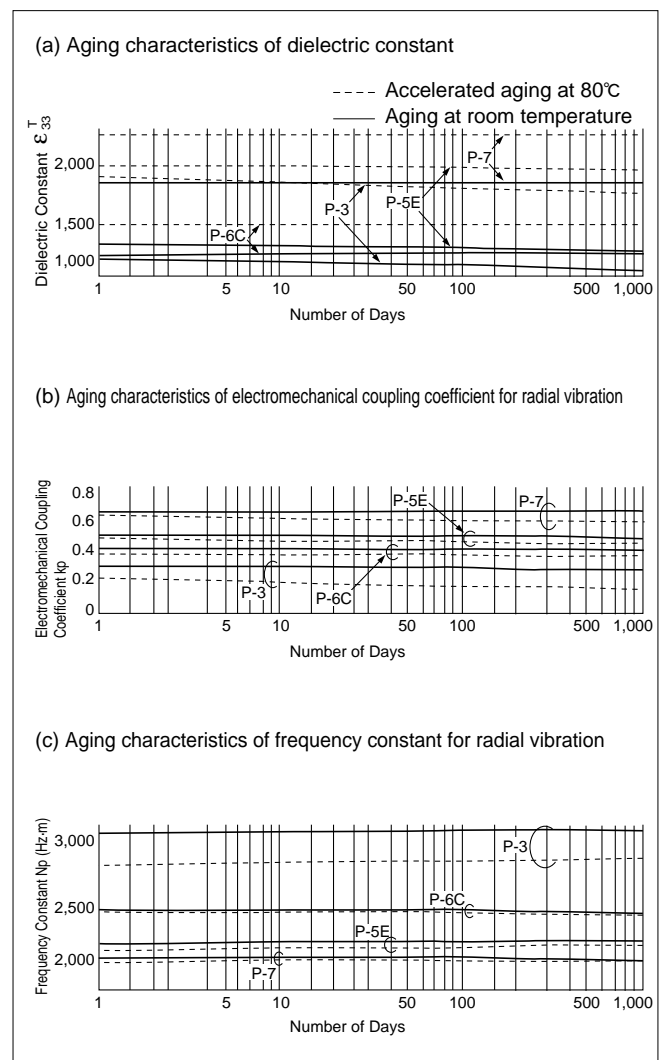
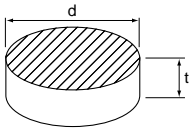
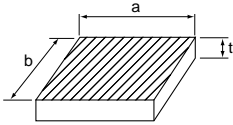
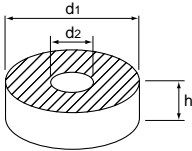

Fig. 8 Aging Characteristics of Various Materials

4 Murata's Piezoelectric Ceramics (PIEZOTITE®)

1. Shapes / Part Numbering

PIEZOTITE® by Murata is available in various forms as shown in Fig. 9.

Shape	Diagram	Vibration Mode	Part Numbering (Ex.)
Disk		Radial Thickness	7 D -10 -9000 -1 ① ② ③ ④ ⑤ ① Indicates material P-7 ② Indicates disk cylinder ③ Diameter d (mm) ④ Resonant frequency (thickness mode) (kHz) ⑤ Product ID
Rectangular Plate		Thickness Length	7 R -34 -23 -6700 ① ② ③ ④ ⑤ ① Indicates material P-7 ② Indicates rectangular plate or pillar ③ Length a (mm) ④ Width b (mm) ⑤ Resonant frequency (thickness mode) (kHz)
Ring		Thickness	6E C -11 -3R9 -1000 ① ② ③ ④ ⑤ ① Indicates material P-6E ② Indicates ring ③ Outer diameter d1 (mm) ④ Inner diameter d2 (mm) ⑤ Resonant frequency (thickness mode) (kHz)

The capital letter "R" expresses significant digits.

Fig. 9 Shapes of Murata's Piezoelectric Ceramics

2. Standard Models and Specifications

Table 3 shows standard models of PIEZOTITE® and specifications.

	Part Number	Dimensions (mm)	Resonant Frequency (kHz)	Capacitance (pF)
Disk	7D-10-9000-1	∅10×0.2t	200 (Radial mode)	5200
Rectangular Plate	5ER-22-22-451	22×22×4.4t	111 (Length mode)	1200
	7R-34-23-6700	34×23×0.3t	42 (Length mode)	42000
Ring	6CC-21-15-700	∅21×∅15×2.85t	66 (Radial mode)	450
	6EC-11-3R9-1000	∅11×∅3.9×2.0t	160 (Radial mode)	480

Table 3 Standard Models of PIEZOTITE® and Specifications

3. Notice

Do not touch the component with bare hand because electrode may damaged.

5 Piezoelectric Ceramics (PIEZOTITE®) Sensors

Piezoelectric ceramics transform electrical energy into mechanical energy and vice versa. Fig. 10 shows our PIEZOTITE® in applications which utilize this basic function of piezoelectric ceramics as an electrical-mechanical energy transducer.

In addition to the current line of products, Fig. 10 also lists some prototypes still under development (*1). Please consult

us concerning custom specifications and production of these new products. The application products are shown in , which are explained in detail on the following pages. For other products not shown in Fig. 10, please contact us. Items marked with an asterisk (*1) in Fig. 10 are available with individual catalogs and application manuals. For more details, refer to those related materials.

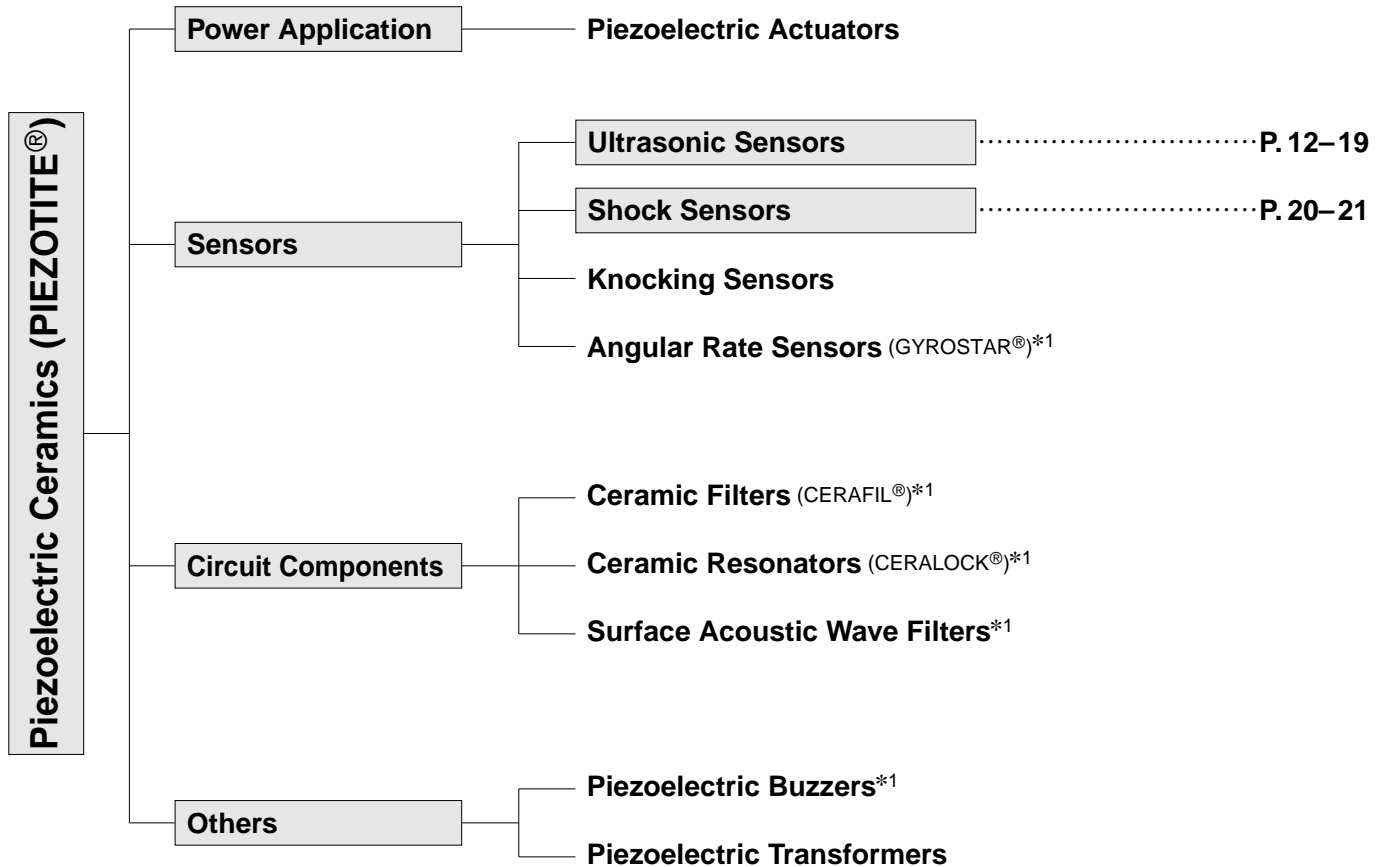

Fig. 10 Piezoelectric Ceramics (PIEZOTITE®)

Piezoelectric Ceramics (PIEZOTITE®) Sensors



Ultrasonic Sensors

Open Structure Type

■ Features

1. Compact and light weight.
2. High sensitivity and sound pressure.
3. High reliability.

■ Applications

Burglar alarms, Range finders, Automatic doors, Remote control.



MA40S4R/S

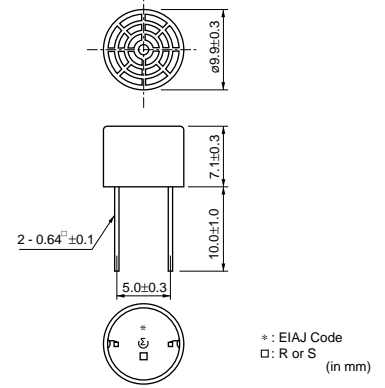

MA40S5

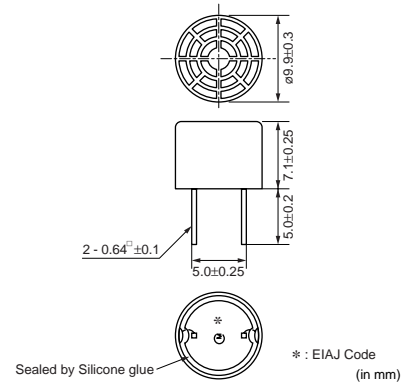

5

Part Number	Structure	Using Method	Nominal Freq. (kHz)	Overall Sensitivity (mVp-p)	Sensitivity (dB)	S.P.L. (dB)	Directivity (°)	Cap. (pF)	Operating Temp. Range (°C)	Detectable Range (m)	Max. Input Voltage (Vp-p)
MA40S4R	Open struct.	Receiver	40	-	-63 typ.	-	80 (typ.)	2550	-40 to 85	0.2 to 4	-
MA40S4S	Open struct.	Transmitter	40	-	-	120 typ.	80 (typ.)	2550	-40 to 85	0.2 to 4	20 40kHz square waves, Continuous signal
MA40S5	Open struct.	Dual Use	40	20 +20/-10	-	-	60 (typ.)	2550	-40 to 85	0.3 to 2	20 40kHz square waves, 16pulses per 100ms

Distance: 30cm, Sensitivity: 0dB=10V/Pa, Sound pressure level: 0dB=20μPa. Refer P19.

The sensor can be used in the operating temperature range.

Please refer to individual specifications for the temperature drift of Sensitivity/Sound pressure levels or environmental characteristics in that temperature range.

Directivity and detectable range are typical values. They can be changed by application circuit and fixing method of the sensor.

■ Directivity in Sensitivity

MA40S4R

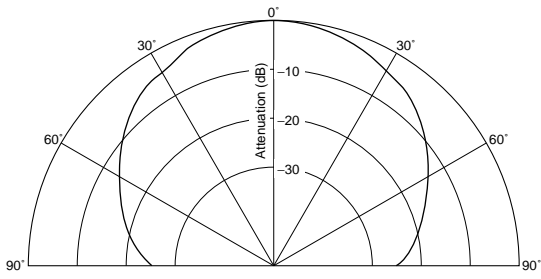

■ Directivity in S. P. L.

MA40S4S

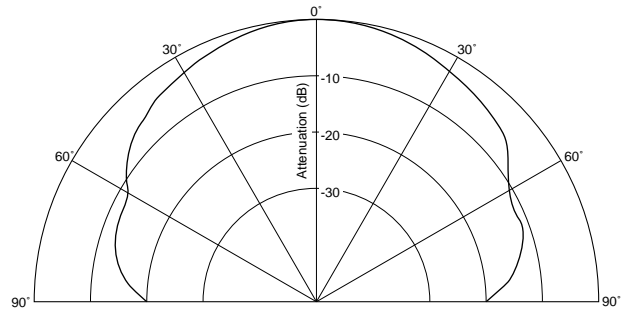

■ Directivity in Overall Sensitivity

MA40S5

Beam Pattern

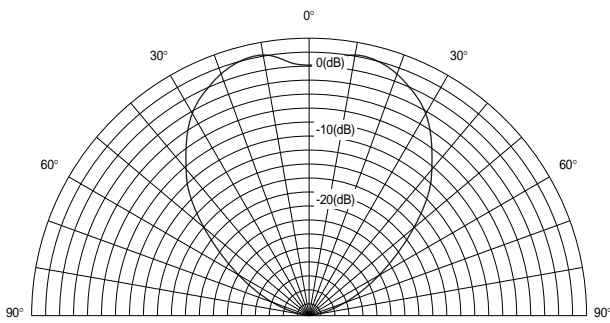

■ Sensitivity - Freq. Characteristics

MA40S4R

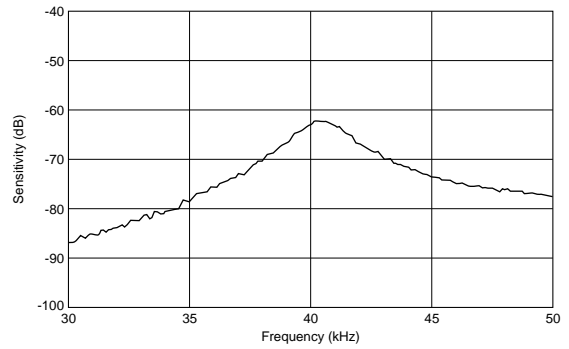

■ S. P. L. - Freq. Characteristics

MA40S4S

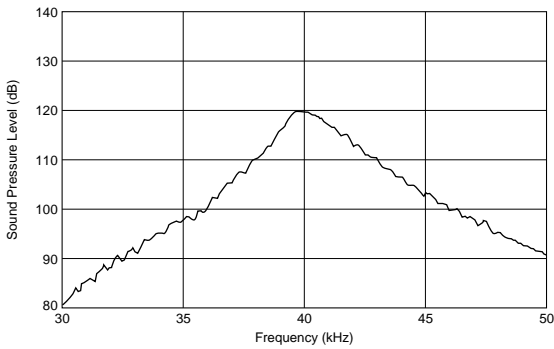

5

Water Proof Type Symmetric Directivity

■ Features

1. Compact and light weight.
2. High sensitivity and sound pressure.
3. High reliability.

■ Applications

Back sonar of automobiles, Parking meters, Water level meters.



MA40E7R/S

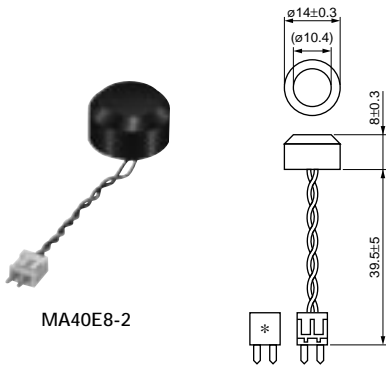
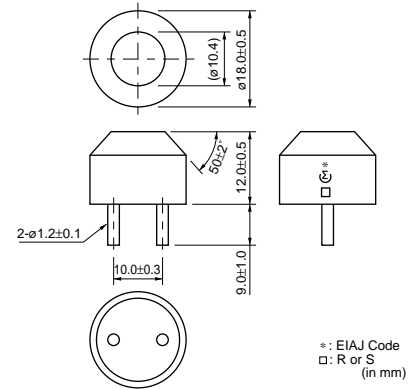

MA40E8-2

Lead wire : AWG30, Red, Black
Connector Pitch : 2mm
* : EIAJ Code

(in mm)



MA40MC10-1B

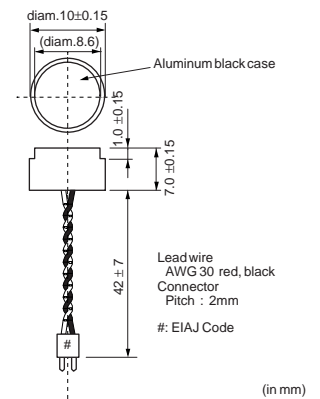

(in mm)

Part Number	Structure	Using Method	Nominal Freq. (kHz)	Overall Sensitivity	Sensitivity (dB)	S.P.L. (dB)	Directivity (°)	Cap. (pF)	Operating Temp. Range (°C)	Detectable Range (m)	Max. Input Voltage (Vp-p)
MA40E7R	Water proof	Receiver	40	-	-74 min.	-	100 (typ.)	2200	-30 to 85	0.2 to 3	-
MA40E7S	Water proof	Transmitter	40	-	-	106 min.	100 (typ.)	2200	-30 to 85	0.2 to 3	100 40kHz square waves, 16pulses per 100ms
MA40E8-2	Water proof	Dual Use	40	-	-85 min.	106 min.	75 (typ.)	2800	-30 to 85	0.2 to 1.5	160 40kHz square waves, 32pulses per 60ms
MA40MC10-1B	Water proof	Dual Use	40	-	-86 min.	104 min.	100 (typ.)	2400	-40 to 85	0.2 to 1.5	160 40kHz square waves, 32pulses per 60ms

Distance: 30cm, Sensitivity: 0dB=10V/Pa, Sound pressure level: 0dB=20μPa. Refer P19.

The sensor can be used in the operating temperature range.

Please refer to individual specifications for the temperature drift of Sensitivity/Sound pressure levels or environmental characteristics in that temperature range.

Directivity and detectable range are typical values. They can be changed by application circuit and fixing method of the sensor.

■ Directivity in Sensitivity

MA40E7R

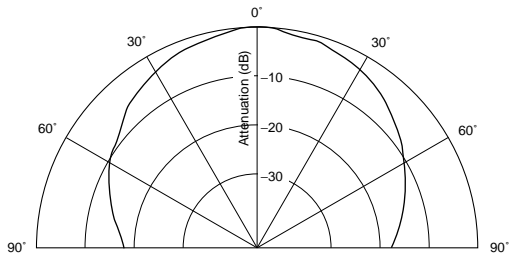

■ Directivity in S. P. L.

MA40E7S

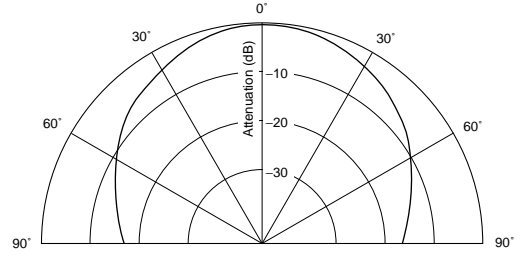

■ Directivity in Overall Sensitivity

MA40E8-2

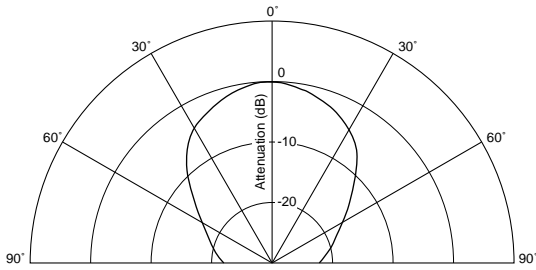

MA40MC10-1B

Beam Pattern

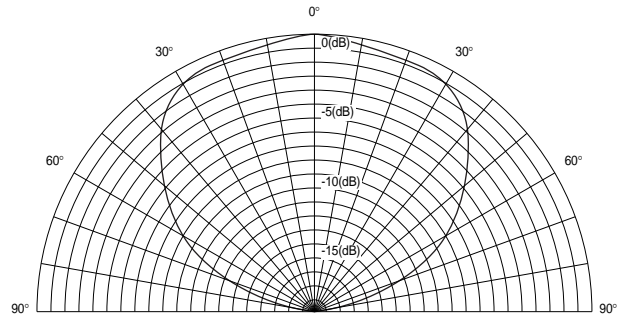

■ Sensitivity - Freq. Characteristics

MA40E7R

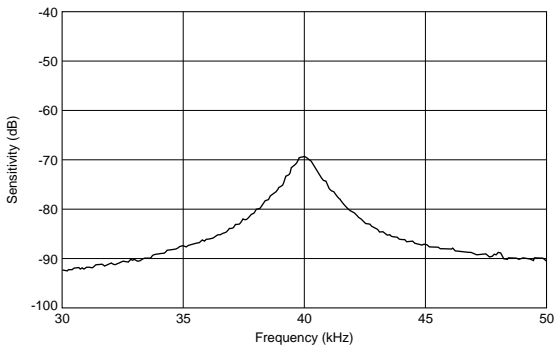

■ S. P. L. - Freq. Characteristics

MA40E7S

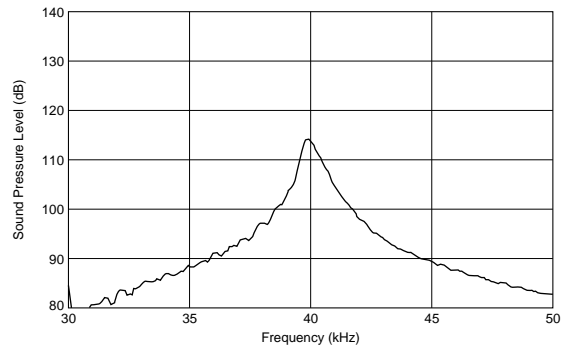

5

Water Proof Type Asymmetric Directivity

■ Features

1. Compact and light weight.
2. High sensitivity and sound pressure.
3. High reliability.

■ Applications

Back sonar of automobiles, Parking meters, Water level meters,



MA40MF14-5B

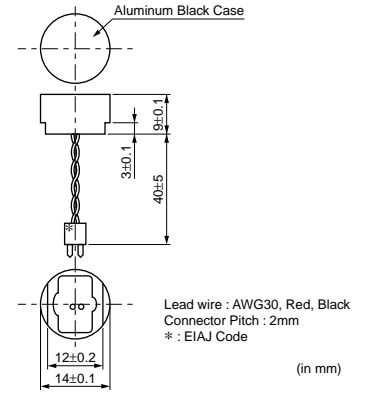

Part Number	Structure	Using Method	Nominal Freq. (kHz)	Overall Sensitivity	Sensitivity (dB)	S.P.L. (dB)	Directivity (°)	Cap. (pF)	Operating Temp. Range (°C)	Detectable Range (m)	Max. Input Voltage (Vp-p)
MA40MF14-5B	Water proof	Dual Use	40	-	-87 min.	103 min.	110 x50° (typ.)	4400	-40 to 85	0.2 to 1.5	160 40kHz square waves, 32pulses per 60ms
MA48MF14-5B	Water proof	Dual Use	48	-	-90 min.	101 min.	100 x40° (typ.)	4200	-40 to 85	0.2 to 1.5	160 40kHz square waves, 32pulses per 60ms

Distance: 30cm, Sensitivity: 0dB=10V/Pa, Sound pressure level: 0dB=20μPa. Refer P19.

The sensor can be used in the operating temperature range.

Please refer to individual specifications for the temperature drift of Sensitivity/Sound pressure levels or environmental characteristics in that temperature range.

Directivity and detectable range are typical values. They can be changed by application circuit and fixing method of the sensor.

5

■ Directivity in Overall Sensitivity

MA40MF14-5B

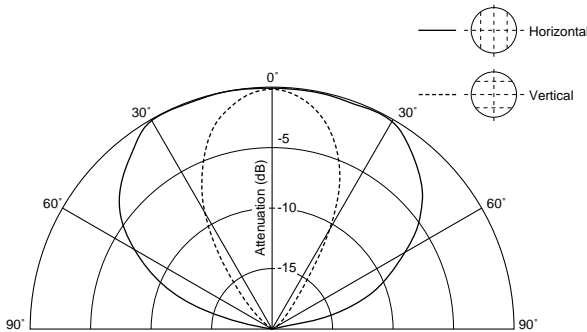

MA48MF14-5B

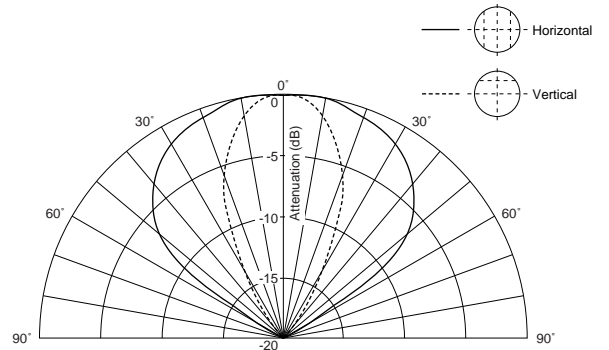

High Frequency Type

■ Features (MA_A1)

1. Compact and light weight
2. High sensitivity and sound pressure
3. High reliability

■ Applications

Approach switch for FA, Distance meter, Water or liquid level meters.

■ Features (MA_D1)

1. Short ringing time
2. Wide bandwidth & quick response
3. Stable output over operating temp.range

■ Applications

1. Proximity switch for FA and Robot
2. Distance meter
3. Double feed detection for papers or banknotes



MA80A1

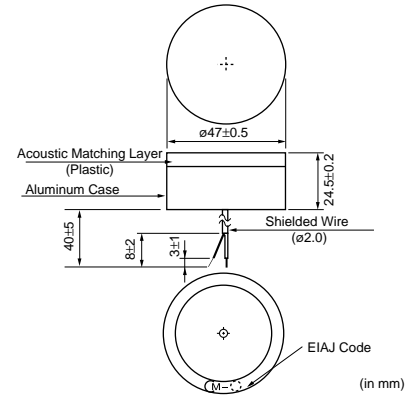

MA200A1

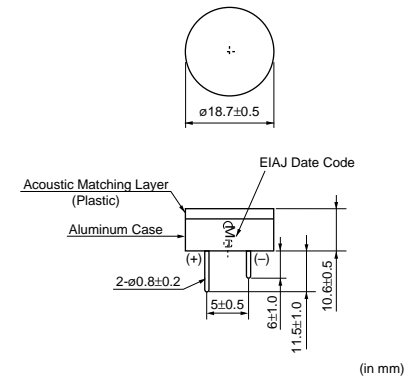

MA400A1

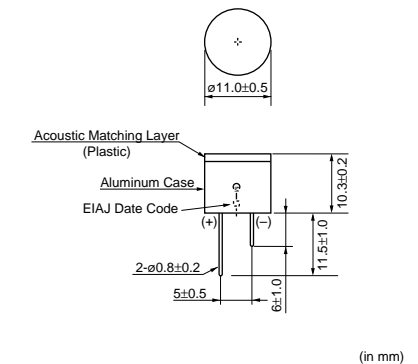

MA200D1-1

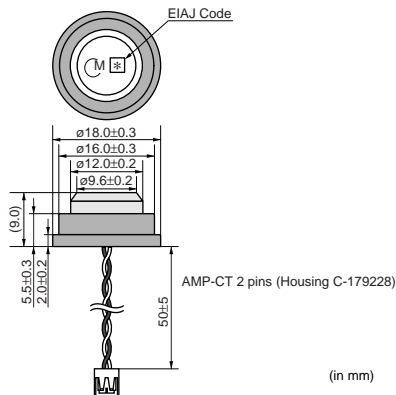

MA300D1-1

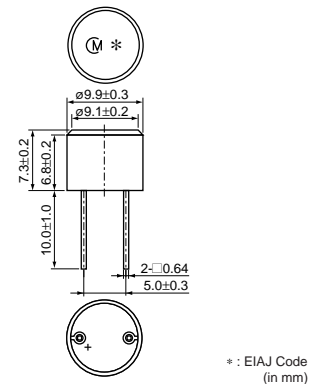

* : EIAJ Code (in mm)

5

Part Number	Structure	Using Method	Nominal Freq. (kHz)	Overall Sensitivity (dB)	Sensitivity	S.P.L.	Directivity (°)	Cap. (pF)	Operating Temp. Range (°C)	Detectable Range (m)	Max. Input Voltage (Vp-p)
MA80A1	High frequency type	Dual Use	75	-47 min. 0dB=18Vpp at 50cm	-	-	7 (typ.)	-	-10 to 60	0.5 to 5	120 75kHz square waves, 45pulses per 50ms
MA200A1	High frequency type	Dual Use	200	-54 min. 0dB=18Vpp at 20cm	-	-	7 (typ.)	-	-30 to 60	0.2 to 1	120 200kHz square waves, 50pulses per 20ms
MA200D1-1	High frequency type	Dual Use	220	1.0V to 2.5V	-	-	20 (Max.)	2300	-20 to 70	0.1 to 0.3	50 220kHz square waves, 5pulses per 4.5ms
MA300D1-1	High frequency type	Dual Use	300	1.5V min.	-	-	11 (Max.)	1300	-20 to 70	0.1 to 0.3	50 300kHz square waves, 5pulses per 3.3ms
MA400A1	High frequency type	Dual Use	400	-74 min. 0dB=18Vpp at 10cm	-	-	7 (typ.)	-	-30 to 60	0.06 to 0.3	120 400kHz square waves, 50pulses per 10ms

The sensor can be used in the operating temperature range.

Please refer to individual specifications for the temperature drift of Sensitivity/Sound pressure levels or environmental characteristics in that temperature range.

Directivity, detectable range and resolution are typical values. They can be changed by application circuit and fixing method of the sensor.

■ Directivity in Overall Sensitivity

MAXXA1 Series

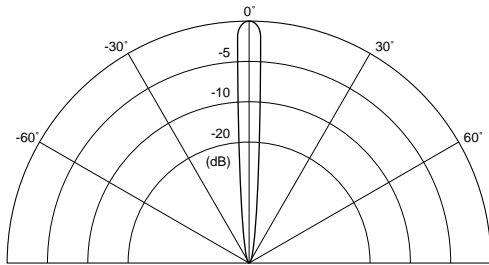

MA200D1-1

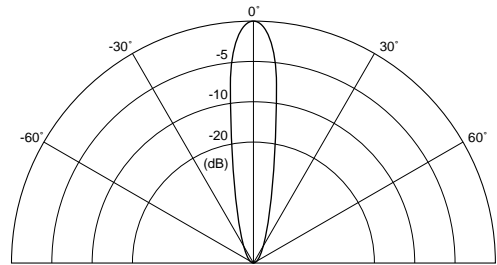

MA300D1-1

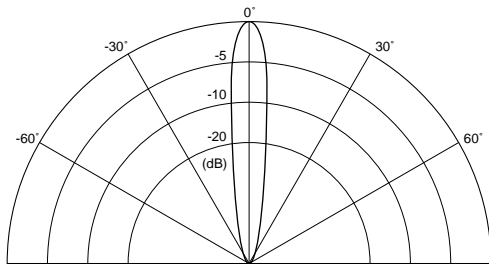

5

Data/Notice/Part Numbering

■ Test System

Sensitivity

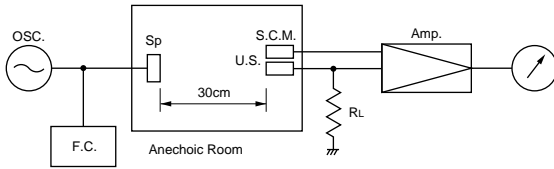

RL : 3.9kΩ
 U.S. : Ultrasonic Sensor
 S.C.M. : Standard Capacitor Microphone (Brüel&Kjær 4135)
 Amp. : Amplifier (Brüel&Kjær 2610)
 OSC. : Oscillator
 Sp. : Tweeter
 F.C. : Frequency Counter

Sound pressure level

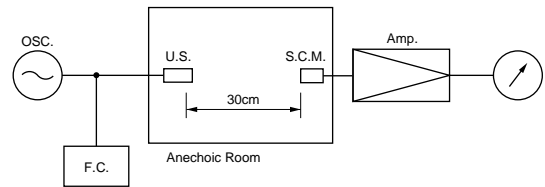

U.S. : Ultrasonic Sensor (Brüel&Kjær 4135)
 S.C.M. : Standard Capacitor Microphone (Brüel&Kjær 2610)
 Amp. : Amplifier
 Input Voltage : 10 Vrms
 F.C. : Frequency Counter

Over all sensitivity

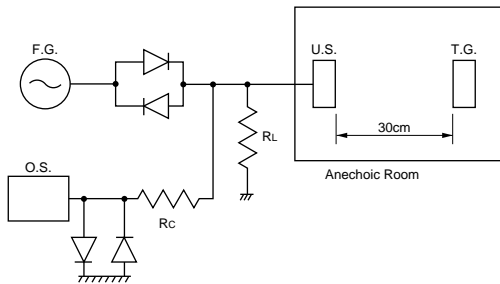

RL : 3.9kΩ Rc=1kΩ
 U.S. : Ultrasonic Sensor
 T.G. : Target (Aluminum plate 100mm x 100mm)
 F.G. : Function Generator (40kHz square waves, 10Vp-p 16pulses per 100ms)
 O.S. : Oscilloscope

■ Notice (Soldering and Mounting)

1. Pay attention to the mounting position as these sensors have directivity.
2. Please avoid applying DC-bias by connecting DC blocking capacitor or some other way because, otherwise, the component may be damaged.
3. Do not use in water.

● Part Numbering

Ultrasonic Sensors

(Part Number)

MA	40MF	14	-5N	-M
----	------	----	-----	----

- ① Product ID
- ② Series
- ③ Characteristics
- ④ Individual Specification Code
- ⑤ Packaging

* "(Part Number)" shows only an example which might be different from actual part number.
 * Any other definitions than "① Product ID" might have different digit numbers from actual part number.

Piezoelectric Ceramics (PIEZOTITE®) Sensors



Shock Sensors

The piezoelectric element produces a voltage which is proportional to the acceleration of an impact or a vibration to which it is exposed. The shock sensor utilizes piezoelectric ceramics to convert the energy of impact into a proportional electrical signal. The piezoelectric shock sensor uses a "unimorph" diaphragm which consists of a piezoelectric ceramic disk laminated to a metal disk. The diaphragm is supported along its circumference in a housing. The sensor features compact, lightweight design, and is suitable for a wide range of applications requiring impact and vibration sensing.

■ Features

1. Compact, lightweight design.
2. High sensitivity assures it picks up even microlevel impact and vibration.
3. Rugged construction survives impact and vibration stresses.
4. Requires no bias voltage.

■ Applications

1. Intruder sensors at windows or doors
2. Burglar alarms for showcases and safes
3. Vibration detector for equipment



PKS1-4A1

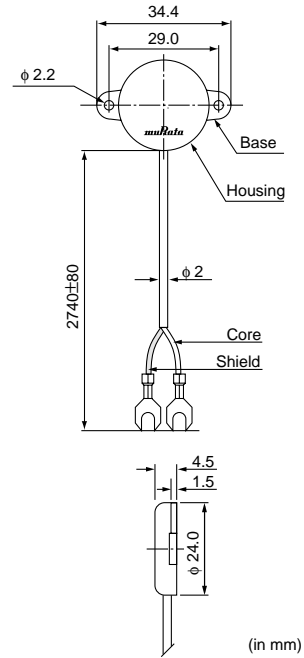

(in mm)



PKS1-4A10

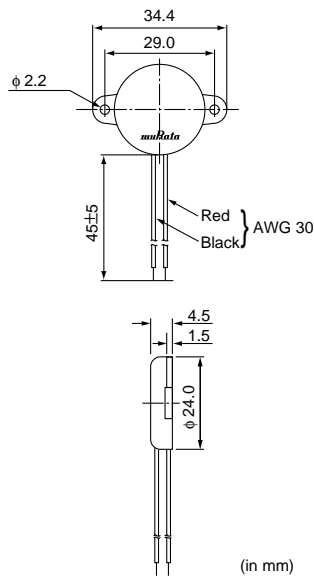

(in mm)



PKS1-4B1

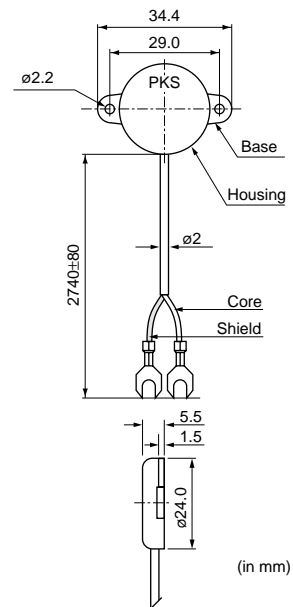

(in mm)

Part Number	Output Voltage	Capacitance	Insulation Resistance
PKS1-4A1	40mV _{o-p} /G typ. (at 25°C, 20MΩ Load, 10Hz - 1kHz)	10000pF±30%	30MΩmin. (at 100V D.C.)
PKS1-4A10		9000pF±30%	
PKS1-4B1	44mV rms ± 15% (at 25°C, 20MΩ Load, 2G, 100Hz)	10000pF±30%	

1G=9.8m/s²
Output Voltage of PKS1-4A1/PKS1-4A10 is reference value.

■ Characteristics Data

● Frequency Response (PKS1-4A1)

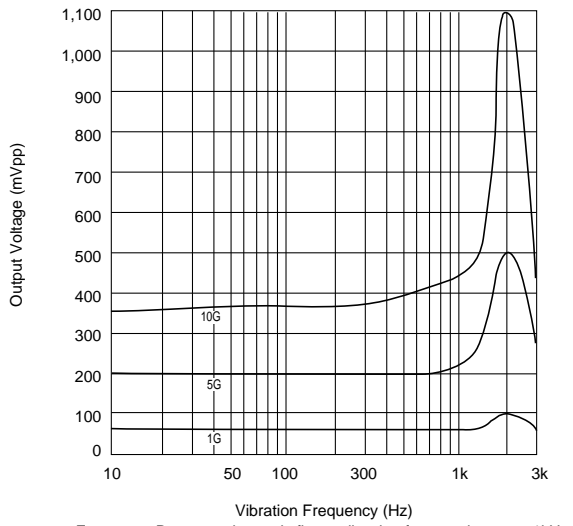

● Output Voltage vs. Impact Response (PKS1-4A1)

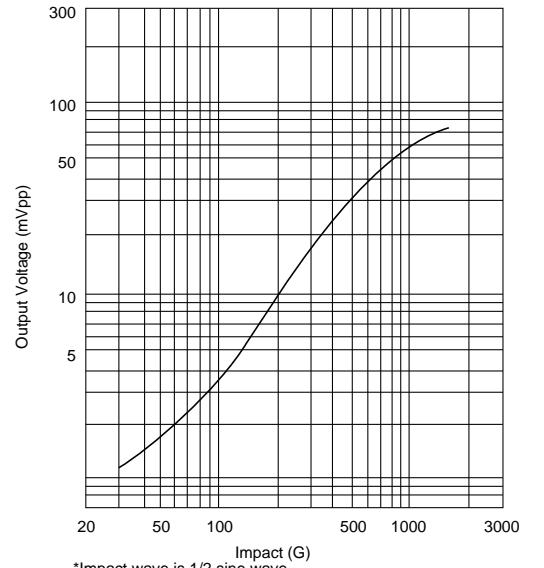

■ Notice

1. The component should be fixed at the place where the main axis of sensor has the same direction as the vibration axis.
2. Please avoid applying DC-bias by connecting DC- blocking capacitor or other methods. Because if DC-bias is added, the component may be damaged.

△Note:

1. Export Control

<For customers outside Japan>

No muRata products should be used or sold, through any channels, for use in the design, development, production, utilization, maintenance or operation of, or otherwise contribution to (1) any weapons (Weapons of Mass Destruction [nuclear, chemical or biological weapons or missiles] or conventional weapons) or (2) goods or systems specially designed or intended for military end-use or utilization by military end-users.

<For customers in Japan>

For products which are controlled items subject to the "Foreign Exchange and Foreign Trade Law" of Japan, the export license specified by the law is required for export.

2. Please contact our sales representatives or product engineers before using the products in this catalog for the applications listed below, which require especially high reliability for the prevention of defects which might directly damage a third party's life, body or property, or when one of our products is intended for use in applications other than those specified in this catalog.

- | | |
|-----------------------------|--|
| ① Aircraft equipment | ② Aerospace equipment |
| ③ Undersea equipment | ④ Power plant equipment |
| ⑤ Medical equipment | ⑥ Transportation equipment (vehicles, trains, ships, etc.) |
| ⑦ Traffic signal equipment | ⑧ Disaster prevention / crime prevention equipment |
| ⑨ Data-processing equipment | ⑩ Application of similar complexity and/or reliability requirements to the applications listed above |

3. Product specifications in this catalog are as of May 2008. They are subject to change or our products in it may be discontinued without advance notice. Please check with our sales representatives or product engineers before ordering. If there are any questions, please contact our sales representatives or product engineers.

4. Please read rating and △ CAUTION (for storage, operating, rating, soldering, mounting and handling) in this catalog to prevent smoking and/or burning, etc.

5. This catalog has only typical specifications because there is no space for detailed specifications. Therefore, please approve our product specifications or transact the approval sheet for product specifications before ordering.

6. Please note that unless otherwise specified, we shall assume no responsibility whatsoever for any conflict or dispute that may occur in connection with the effect of our and/or a third party's intellectual property rights and other related rights in consideration of your use of our products and/or information described or contained in our catalogs. In this connection, no representation shall be made to the effect that any third parties are authorized to use the rights mentioned above under licenses without our consent.

7. No ozone depleting substances (ODS) under the Montreal Protocol are used in our manufacturing process.