

Features

- Single-Supply Operation from +1.8V ~+5.5V
- Rail-to-Rail Input / Output
- Gain-Bandwidth Product: 350KHz (Typ.@25°C)
- Low Input Bias Current: 20pA (Typ.@25°C)
- Low Offset Voltage: 10uV (Max. @25°C)
- Quiescent Current: 25μA per Amplifier (Typ)
- Operating Temperature: -45°C ~ +125°C
- Zero Drift: 0.05μV/°C (Typ)
- Embedded RF Anti-EMI Filter
- Small Package:
CBM8333 Available in SOT23-5, SC70-5 and SOP-8 Packages
CBM8336 Available in SOP-8, MSOP-8 and DFN-8 Packages
CBM8339 Available in SOP-14 and TSSOP-14 Packages

Application

- Transducer Application
- Temperature Measurements
- Electronics Scales
- Handheld Test Equipment
- Battery-Powered Instrumentation

Description

The CBM833X amplifier is single/ dual/ quad supply, micro-power, zero-drift CMOS operational amplifiers, the amplifiers offer bandwidth of 350 kHz, rail-to-rail inputs and outputs, and single-supply operation from 1.8V to 5.5V. CBM833X uses chopper stabilized technique to provide very low offset voltage (less than 10μV maximum) and near zero drift over temperature. Low quiescent supply current of 25μA per amplifier and very low input bias current of 20pA make the devices an ideal choice for low offset, low power consumption and high impedance applications. The CBM833X offers excellent CMRR without the crossover associated with traditional complementary input stages. This design results in superior performance for driving analog-to-digital converters (ADCs) without degradation of differential linearity.

The CBM8333 is available in SOT23-5, SC70-5 and SOP8 packages. And the CBM8336 is available in SOP8, MSOP8 and DFN-8 packages. The CBM8339 Quad is available in Green SOP-14 and TSSOP-14 packages. The extended temperature range of -45°C to +125°C over all supply voltages offers additional design flexibility.

Catalog

Features.....	1
Application.....	1
Description.....	1
Catalog.....	2
Pin Configurations.....	3
Absolute Maximum Ratings.....	5
Electrical Characteristics.....	6
Typical Performance characteristics.....	7
Application Notes.....	9
Typical Application Circuits.....	10
Differential amplifier.....	11
Low Pass Active Filter.....	11
Instrumentation Amplifier.....	12
Package Outline Dimensions.....	13
DFN-8.....	13
MSOP-8.....	14
TSSOP-14.....	15
SOIC-8(SOP8).....	16
SOIC-14(SOP14).....	17
SOT23-5.....	18
SC70-5.....	19
Package/Ordering Information.....	20

Pin Configurations

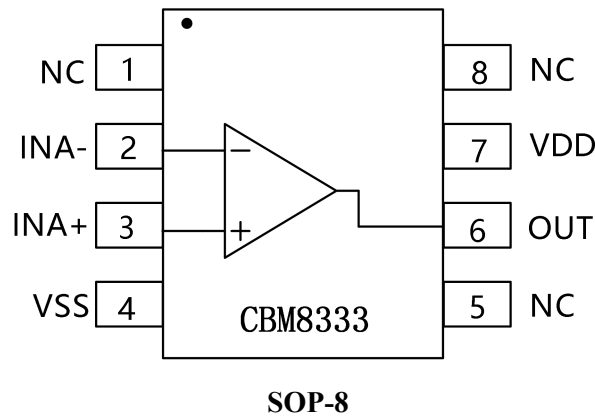
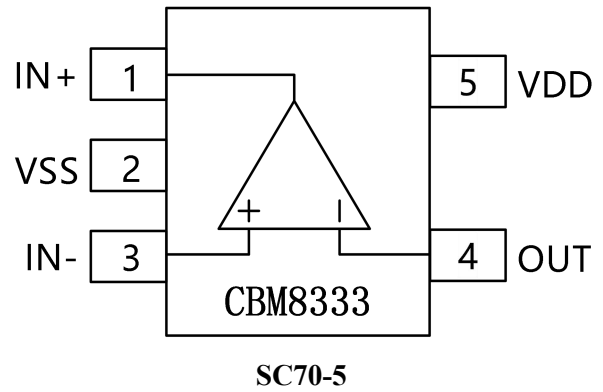
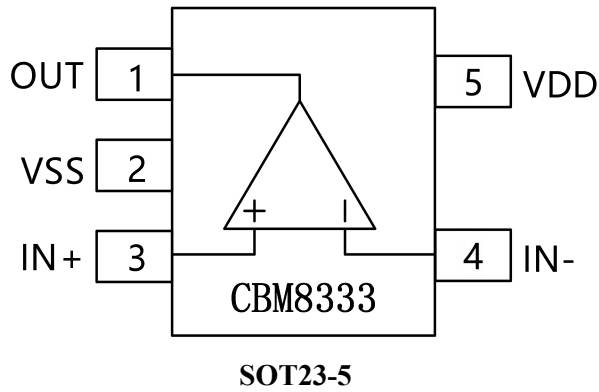

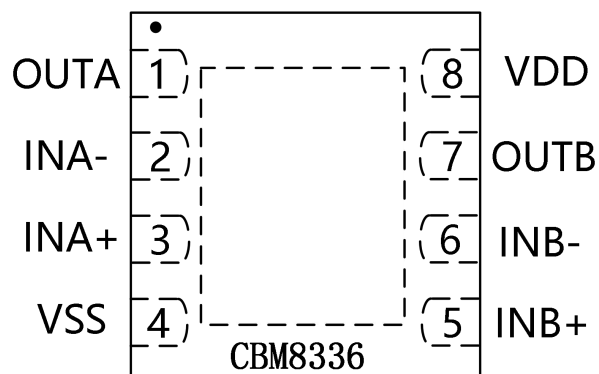

DFN-8

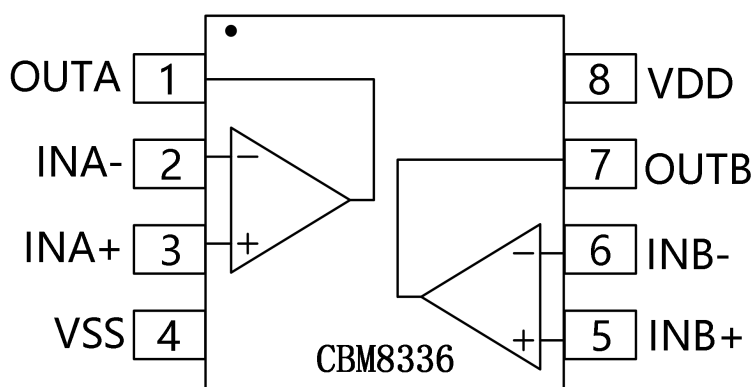

MSOP-8/SOP-8

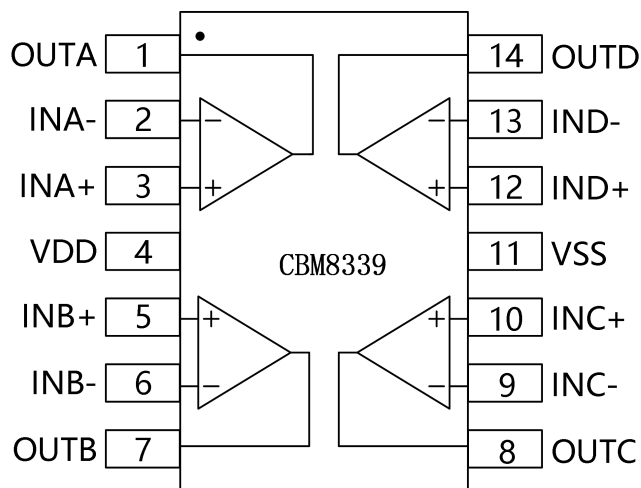

SOP-14/TSSOP-14

Absolute Maximum Ratings

Condition	Min	Max
Power Supply Voltage (V_{DD} to V_{SS})	-0.5V	+7.5V
Analog Input Voltage (IN+ or IN-)	$V_{SS}-0.5V$	$V_{DD}+0.5V$
PDB Input Voltage	$V_{SS}-0.5V$	+7V
Operating Temperature Range	-45°C	+125°C
Junction Temperature	+160°C	
Storage Temperature Range	-55°C	+150°C
Lead Temperature (soldering, 10sec)	+260°C	
Package Thermal Resistance ($T_A=+25^\circ\text{C}$)		
SOP-8, θ_{JA}	125°C/W	
MSOP-8, θ_{JA}	216°C/W	
SOT23-5, θ_{JA}	190°C/W	
ESD Susceptibility		
HBM	6KV	
MM	400V	

Note: Stress greater than those listed under Absolute Maximum Ratings may cause permanent damage to the device. This is a stress rating only and functional operation of the device at these or any other conditions outside those indicated in the operational sections of this specification are not implied. Exposure to absolute maximum rating conditions for extended periods may affect reliability.

Electrical Characteristics

(At $V_S=5V$, $T_A = +25^\circ C$, $V_{CM} = V_S/2$, $R_L = 10k\Omega$, unless otherwise noted.)

PARAMETER	CONDITION	MIN	TYP	MAX	UNIT
INPUT CHARACTERISTICS					
Input Offset Voltage (V_{OS})			2	10	μV
Input Bias Current (I_B)			20		μA
Input Offset Current (I_{OS})			10		μA
Common-Mode Rejection Ratio (CMRR)	$V_{CM} = 0V$ to $5V$		110		dB
Large Signal Voltage Gain (A_{VO})	$R_L = 10k\Omega$, $V_O = 0.3V$ to $4.7V$		145		dB
Input Offset Voltage Drift ($\Delta V_{OS}/\Delta T$)			50		$nV/^\circ C$
OUTPUT CHARACTERISTICS					
Output Voltage High (V_{OH})	$R_L = 100k\Omega$ to $-V_S$		4.998		V
	$R_L = 10k\Omega$ to $-V_S$		4.994		V
Output Voltage Low (V_{OL})	$R_L = 100k\Omega$ to $+V_S$		5		mV
	$R_L = 10k\Omega$ to $+V_S$		20		mV
Short Circuit Limit (I_{SC})	$R_L = 10\Omega$ to $-V_S$		20		mA
Output Current (I_O)			30		mA
POWER SUPPLY					
Power Supply Rejection Ratio (PSRR)	$V_S = 2.5V$ to $5.5V$		115		dB
Quiescent Current (I_Q)	$V_O = 0V$, $R_L = 0\Omega$		25		μA
DYNAMIC PERFORMANCE					
Gain-Bandwidth Product (GBP)	$G = +100$		350		KHz
Slew Rate (SR)	$R_L = 10k\Omega$		0.2		$V/\mu s$
NOISE PERFORMANCE					
Voltage Noise (e_n p-p)	0Hz to 10Hz		1.1		μV_{p-p}
Voltage Noise Density (e_n)	$f = 1kHz$		70		nV/\sqrt{Hz}

Typical Performance Characteristics

($T_A = +25^\circ\text{C}$, $V_S = 5\text{V}$, $R_L = 10\text{k}\Omega$ connected to $V_S/2$ and $V_{OUT} = V_S/2$, unless otherwise noted.)

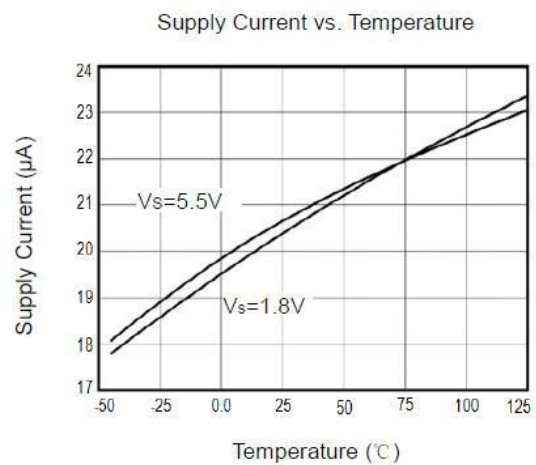
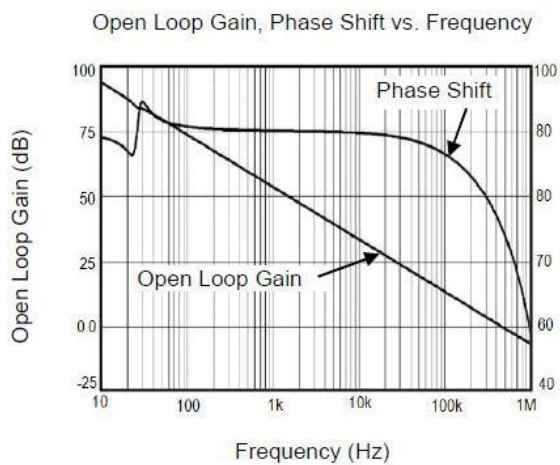
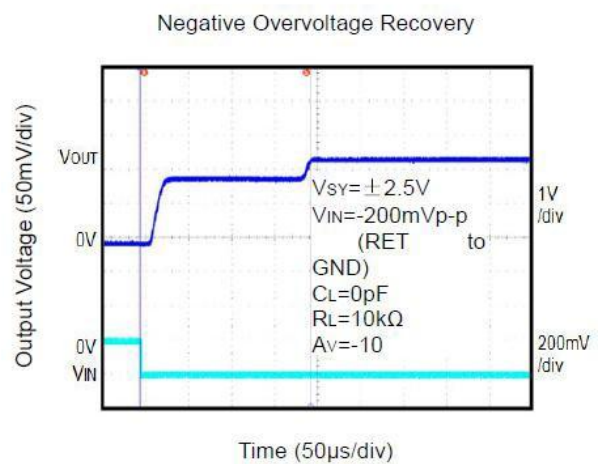
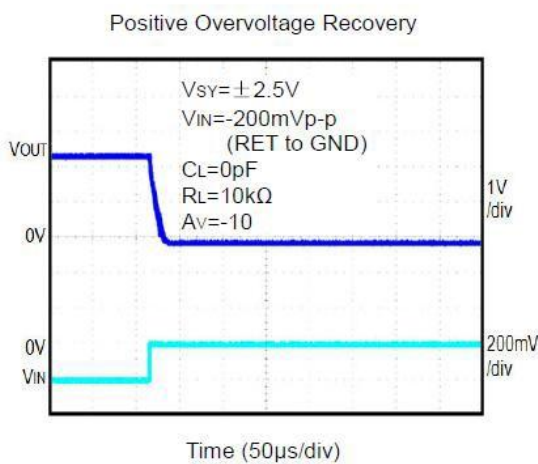
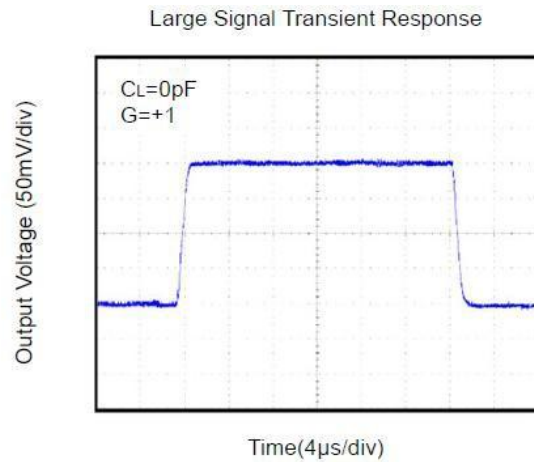
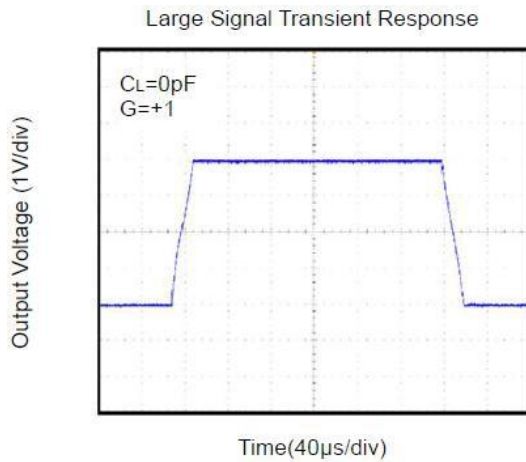

Output Voltage Swing vs. Output Current at +3V

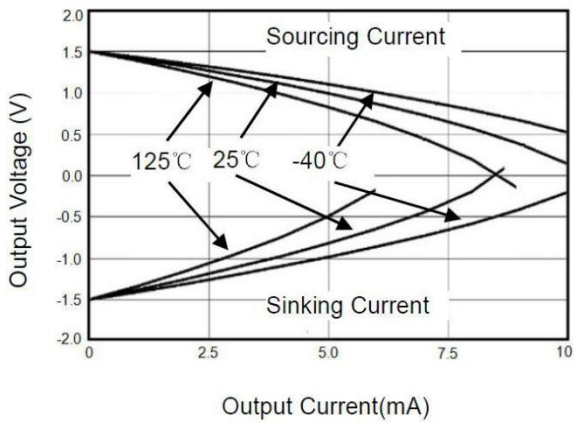

Output Voltage Swing vs. Output Current at +5V

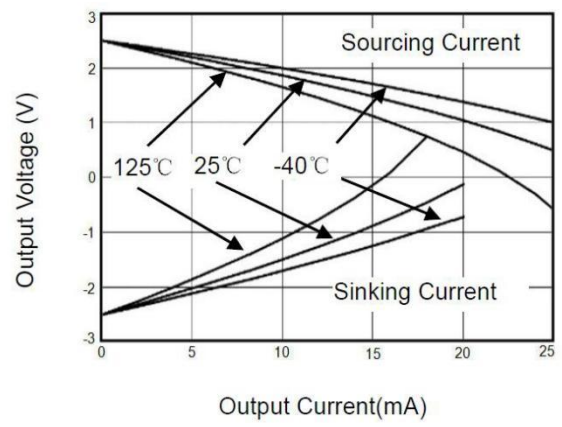

Application Notes

Size

CBM833X series op amps are unity-gain stable and suitable for a wide range of general-purpose applications. The small footprints of the CBM833X series packages save space on printed circuit boards and enable the design of smaller electronic products.

Power Supply Bypassing and Board Layout

CBM833X series operates from a single 1.8V to 5.5V supply or dual $\pm 0.9V$ to $\pm 2.75V$ supplies. For best performance, a $0.1\mu F$ ceramic capacitor should be placed close to the VDD pin in single supply operation. For dual supply operation, both VDD and VSS supplies should be bypassed to ground with separate $0.1\mu F$ ceramic capacitors.

Low Supply Current

The low supply current (typical 25uA per channel) of CBM833X series will help to maximize battery life. They are ideal for battery powered systems

Operating Voltage

CBM833X series operate under wide input supply voltage (1.8V to 5.5V). In addition, all temperature specifications apply from $-45^{\circ}C$ to $+125^{\circ}C$. Most behavior remains unchanged throughout the full operating voltage range. These guarantees ensure operation throughout the single Li-Ion battery lifetime

Rail-to-Rail Input

The input common-mode range of CBM833X series extends 100mV beyond the supply rails (VSS-0.1V to VDD+0.1V). This is achieved by using complementary input stage. For normal operation, inputs should be limited to this range.

Rail-to-Rail Output

Rail-to-Rail output swing provides maximum possible dynamic range at the output. This is particularly important when operating in low supply voltages. The output voltage of CBM833X series can typically swing to less than 5mV from supply rail in light resistive loads ($>100k\Omega$), and 100mV of supply rail in moderate resistive loads ($10k\Omega$).

Capacitive Load Tolerance

The CBM833X family is optimized for bandwidth and speed, not for driving capacitive loads. Output capacitance will create a pole in the amplifier's feedback path, leading to excessive peaking and potential oscillation. If dealing with load capacitance is a requirement of the application, the two strategies to consider are (1) using a small resistor in series with the amplifier's output and the load capacitance and (2) reducing the bandwidth of the amplifier's feedback loop by increasing the overall noise gain. Figure 2. shows a unity gain follower using the series resistor strategy. The resistor isolates the output from the capacitance and, more

importantly, creates a zero in the feedback path that compensates for the pole created by the output capacitance.

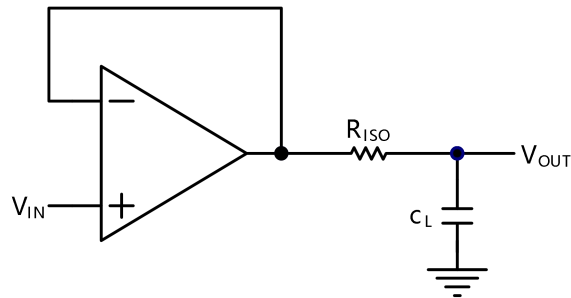

Figure 2. Indirectly Driving a Capacitive Load Using Isolation Resistor

The bigger the R_{ISO} resistor value, the more stable V_{OUT} will be. However, if there is a resistive load R_L in parallel with the capacitive load, a voltage divider (proportional to R_{ISO}/R_L) is formed, this will result in a gain error.

The circuit in Figure 3 is an improvement to the one in Figure 2. R_F provides the DC accuracy by feed-forward the V_{IN} to R_L . C_F and R_{ISO} serve to counteract the loss of phase margin by feeding the high frequency component of the output signal back to the amplifier's inverting input, thereby preserving the phase margin in the overall feedback loop. Capacitive drive can be increased by increasing the value of C_F . This in turn will slow down the pulse response.

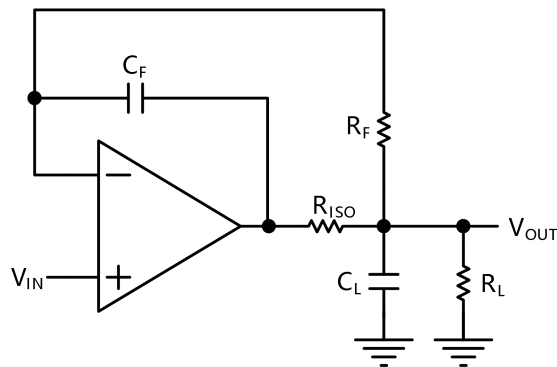

Figure 3. Indirectly Driving a Capacitive Load with DC Accuracy

Typical Application Circuits

Differential amplifier

The differential amplifier allows the subtraction of two input voltages or cancellation of a signal common to the two inputs. It is useful as a computational amplifier in making a differential to single-end conversion or in rejecting a common mode signal. Figure 4. shown the differential amplifier using CBM833X.

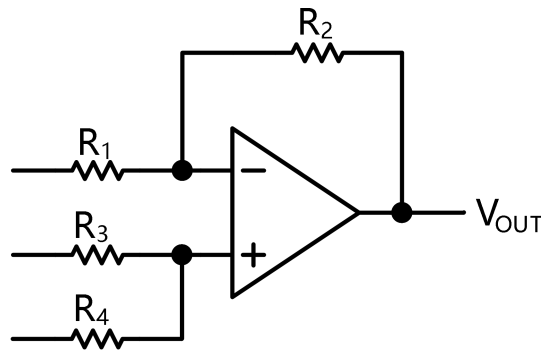

Figure 4. Differential Amplifier

$$V_{OUT} = \left(\frac{R_1 + R_2}{R_3 + R_4} \right) \frac{R_4}{R_1} V_{IN} - \frac{R_2}{R_1} V_{IP} + \left(\frac{R_1 + R_2}{R_3 + R_4} \right) \frac{R_3}{R_1} V_{REF}$$

If the resistor ratios are equal (i.e. $R_1=R_3$ and $R_2=R_4$), then

$$V_{OUT} = \frac{R_2}{R_1} (V_{IP} - V_{IN}) + V_{REF}$$

Low Pass Active Filter

The low pass active filter is shown in Figure 5. The DC gain is defined by $-R_2/R_1$. The filter has a -20dB/decade roll-off after its corner frequency $f_C=1/(2\pi R_3 C_1)$.

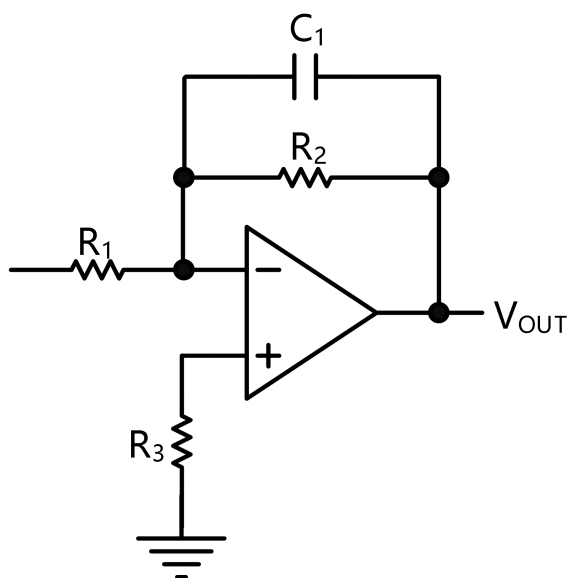

Figure 5. Low Pass Active Filter

Instrumentation Amplifier

The triple CBM833X can be used to build a three-op-amp instrumentation amplifier as shown in Figure 6. The amplifier in Figure 6 is a high input impedance differential amplifier with gain of R_2/R_1 . The two differential voltage followers assure the high input impedance of the amplifier.

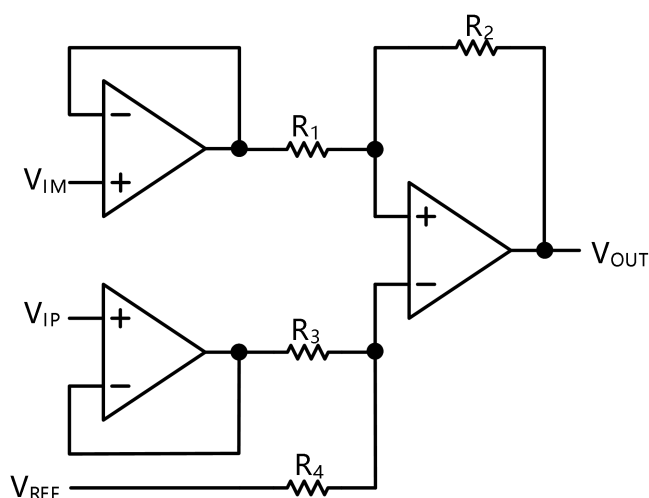
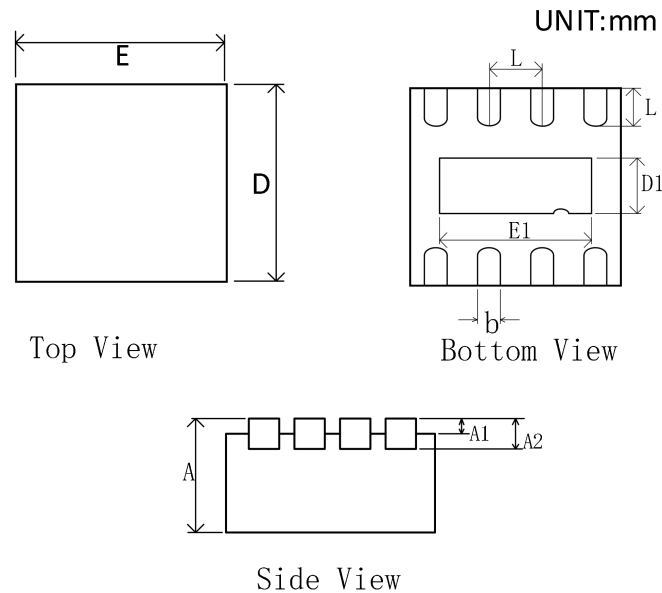

Figure 6. Instrument Amplifier

Package Outline Dimensions

DFN-8



Symbol	Dimensions In Millimeters			Dimensions Inches		
	Min	Nom	Max	Min	Nom	Max
A	0.80	0.85	0.9	0.031	0.033	0.035
A1	0.00	0.02	0.05	0.000	0.001	0.002
A2	0.153	0.203	0.253	0.006	0.008	0.010
b	0.18	0.24	0.30	0.007	0.009	0.012
D	1.9	2.0	2.1	0.075	0.079	0.083
E	1.9	2.0	2.1	0.075	0.079	0.083
D1	0.5	0.6	0.7	0.020	0.024	0.028
E1	1.1	1.2	1.3	0.043	0.047	0.051
e		0.50			0.20	
k	0.2			0.008		
L	0.25	0.35	0.45	0.010	0.014	0.018
A	0.80	0.85	0.9	0.031	0.033	0.035

MSOP-8

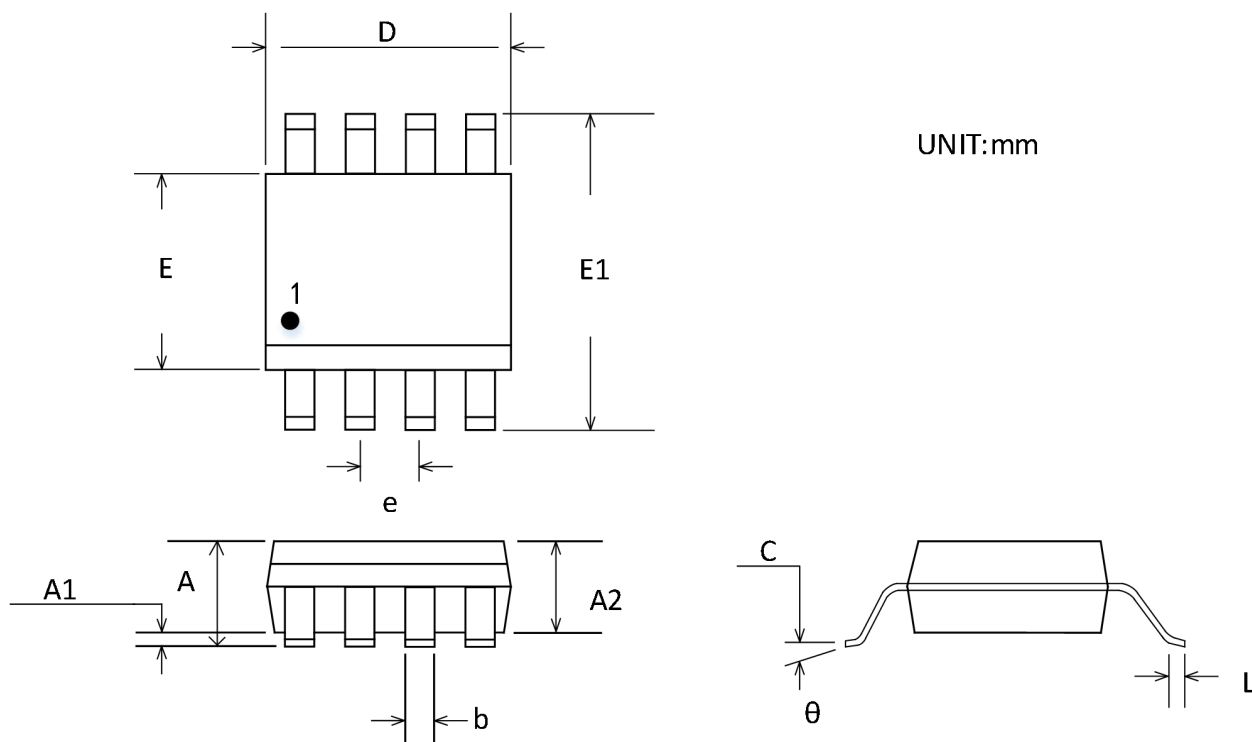

Symbol	Dimensions In Millimeters		Dimensions Inches	
	Min	Max	Min	Max
A	0.820	1.100	0.032	0.043
A1	0.020	0.150	0.001	0.006
A2	0.750	0.950	0.030	0.037
b	0.250	0.380	0.010	0.015
c	0.090	0.230	0.004	0.009
D	2.900	3.100	0.114	0.122
E	2.900	3.100	0.114	0.122
E1	4.750	5.050	0.187	0.199
e	0.650 BSC		0.026 BSC	
L	0.400	0.800	0.016	0.031
θ	0°	6°	0°	6°

TSSOP-14

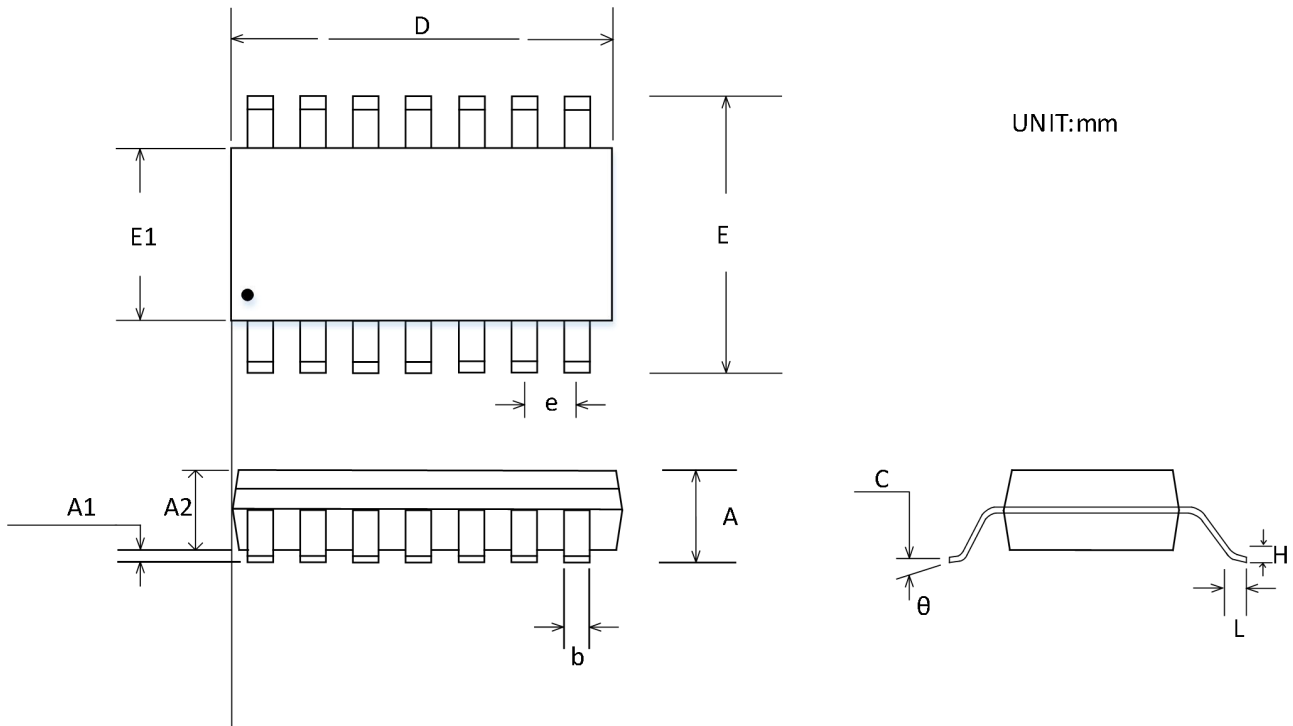

Symbol	Dimensions In Millimeters		Dimensions Inches	
	Min	Max	Min	Max
A		1.200		0.047
A1	0.050	0.150	0.002	0.006
A2	0.800	1.050	0.031	0.041
b	0.190	0.300	0.007	0.012
c	0.090	0.200	0.004	0.008
D	4.860	5.100	0.191	0.201
E	4.300	4.500	0.169	0.177
E1	6.250	6.550	0.246	0.258
e	0.650 BSC		0.026 BSC	
L	0.500	0.700	0.020	0.028
H	0.25 TYP		0.01 TYP	
θ	1°	7°	1°	7°

SOIC-8(SOP8)

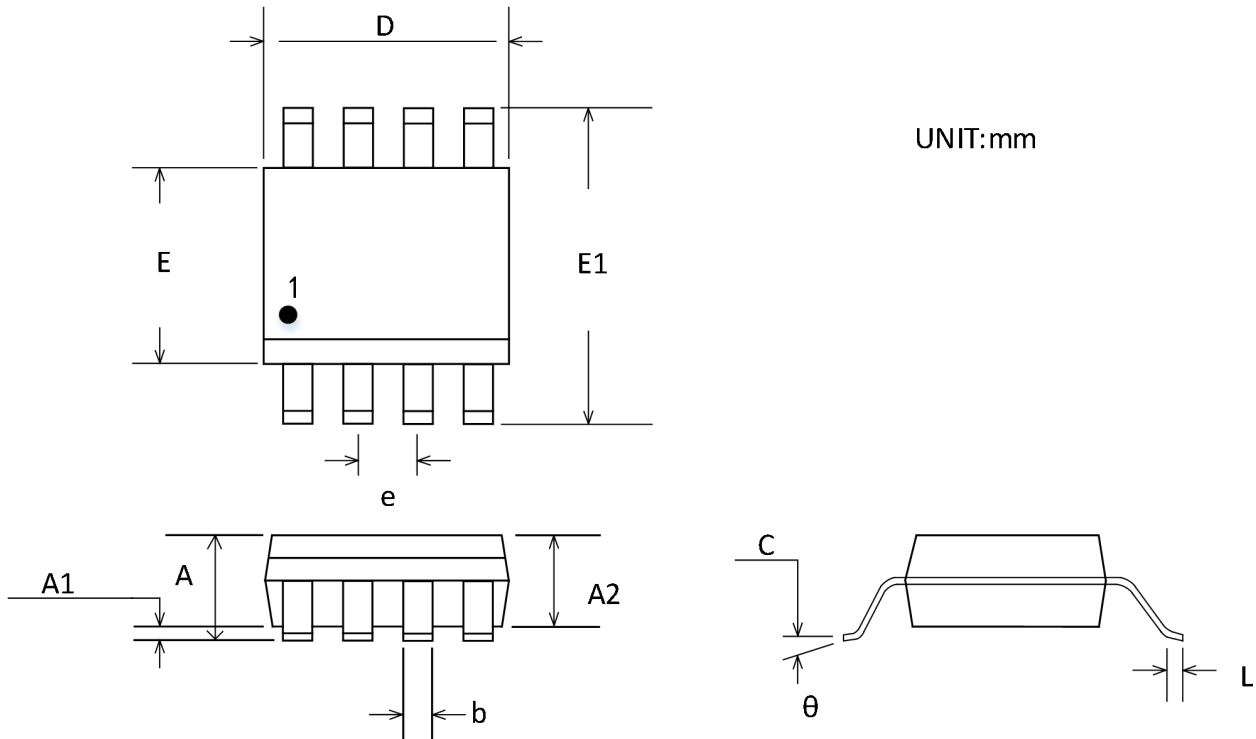

Symbol	Dimensions In Millimeters		Dimensions Inches	
	Min	Max	Min	Max
A	1.350	1.750	0.053	0.069
A1	0.100	0.250	0.004	0.010
A2	1.350	1.550	0.053	0.061
b	0.330	0.510	0.013	0.020
c	0.170	0.250	0.007	0.010
D	4.800	5.000	0.189	0.197
E	5.800	6.200	0.228	0.244
E1	3.800	4.000	0.150	0.157
e	1.270 BSC		0.050 BSC	
L	0.400	1.270	0.016	0.050
θ	0°	8°	0°	8°

SOIC-14(SOP14)

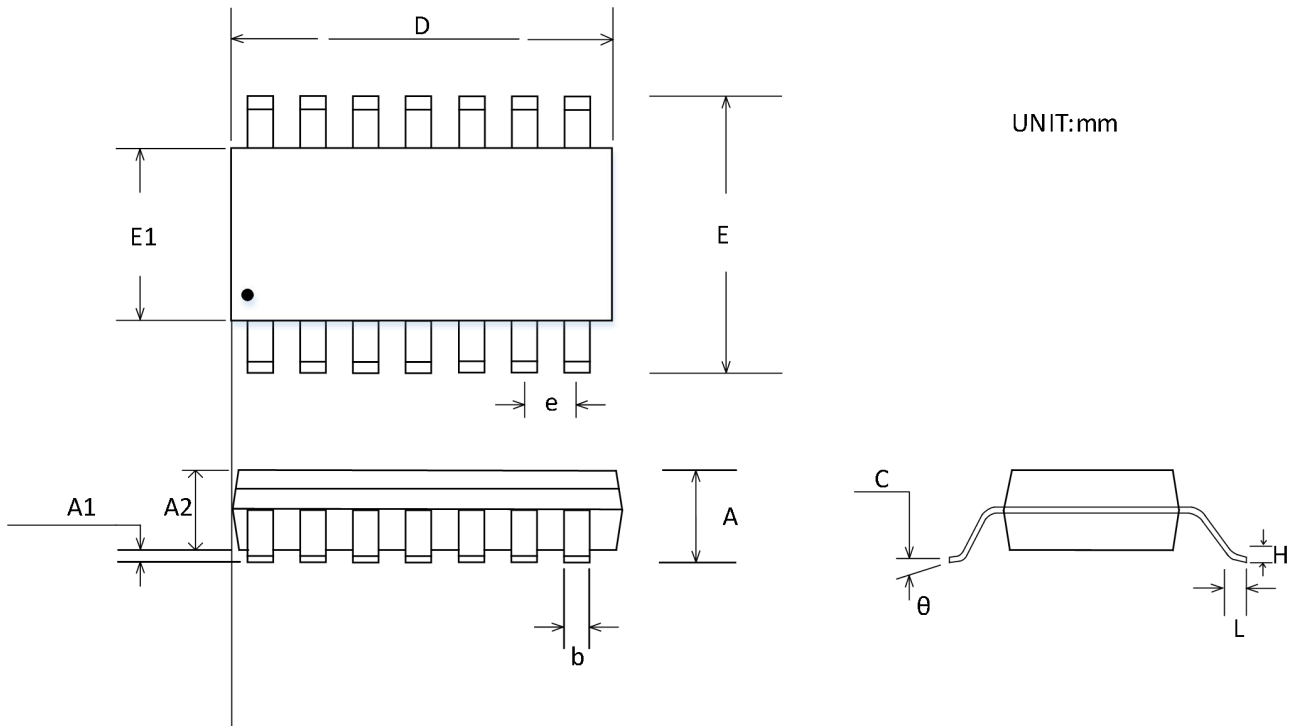

Symbol	Dimensions In Millimeters		Dimensions Inches	
	Min	Max	Min	Max
A	1.350	1.750	0.053	0.069
A1	0.100	0.250	0.004	0.010
A2	1.350	1.550	0.053	0.061
b	0.310	0.510	0.012	0.020
c	0.100	0.250	0.004	0.010
D	8.450	8.850	0.333	0.348
E	5.800	6.200	0.228	0.244
E1	3.800	4.000	0.150	0.157
e	1.270 BSC		0.050 BSC	
L	0.400	1.270	0.016	0.050
R1	0°	8°	0°	8°

SOT23-5

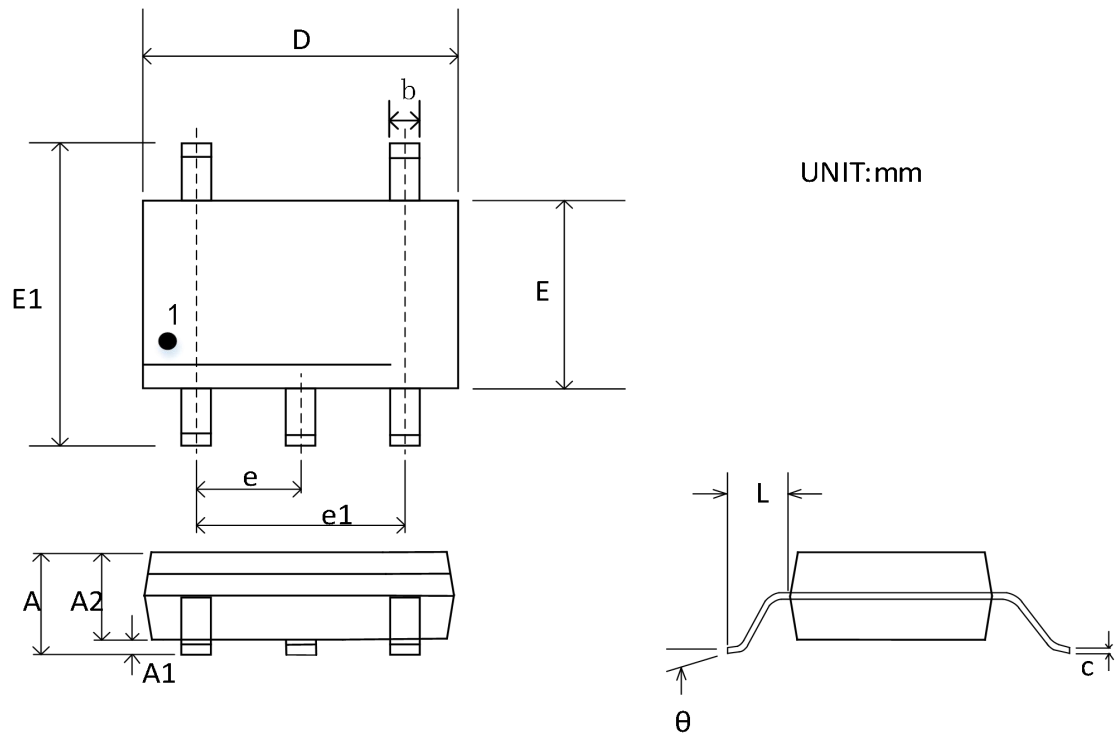

Symbol	Dimensions In Millimeters		Dimensions Inches	
	Min	Max	Min	Max
A	1.050	1.250	0.041	0.049
A1	0.000	0.100	0.000	0.004
A2	1.050	1.150	0.041	0.045
b	0.300	0.500	0.012	0.020
c	0.100	0.200	0.004	0.008
D	2.820	3.020	0.111	0.119
E	1.500	1.700	0.059	0.067
E1	2.650	2.950	0.104	0.116
e	0.950 BSC		0.037 BSC	
e1	1.800	2.000	0.071	0.079
L	0.300	0.600	0.012	0.024
θ	0°	8°	0°	8°

SC70-5

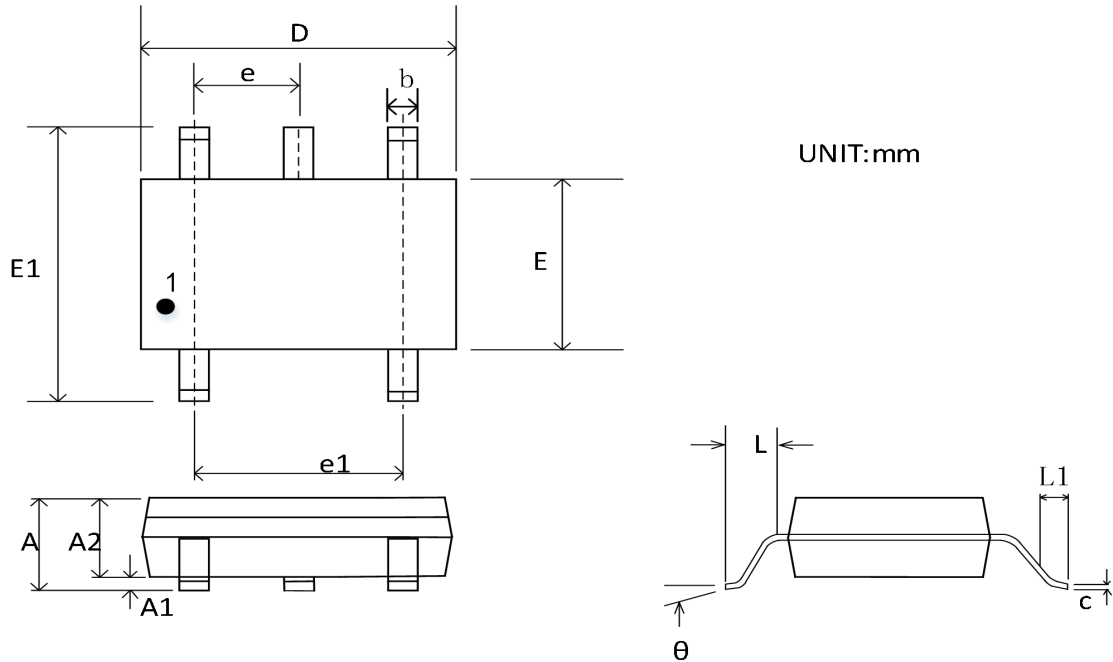

Symbol	Dimensions In Millimeters		Dimensions Inches	
	Min	Max	Min	Max
A	0.900	1.100	0.035	0.043
A1	0.000	0.100	0.000	0.004
A2	0.900	1.000	0.035	0.039
b	0.150	0.350	0.006	0.014
C	0.080	0.150	0.003	0.006
D	2.000	2.200	0.079	0.087
E	1.150	1.350	0.045	0.053
E1	2.150	2.450	0.085	0.096
e	0.650 TYP		0.026TYP	
e1	1.200	1.400	0.047	0.055
L	0.525 REF		0.021 REF	
L1	0.260	0.460	0.010	0.018
θ	0°	8°	0°	8°

Package/Ordering Information

ORDERING NUMBER	TEMPRANGE	PACKAGE	PAKEAGE MARKING	TRANSPOT MEDIA,QUANTILY
CBM8333AST5	-40°C~125°C	SOT23-5	333A	Tape and Reel, 3000
CBM8333ASC7	-40°C~125°C	SC70-5	333C	Tape and Reel, 3000
CBM8333AS8	-40°C~125°C	SOP-8	CBM8333A	Tape and Reel, 2500
CBM8333AS8-RL	-40°C~125°C	SOP-8	CBM8333A	Tape and Reel, 3000
CBM8333AS8-REEL	-40°C~125°C	SOP-8	CBM8333A	Tape and Reel, 4000
CBM8336AS8	-40°C~125°C	SOP-8	CBM8336A	Tape and Reel, 2500
CBM8336AS8-RL	-40°C~125°C	SOP-8	CBM8336A	Tape and Reel, 3000
CBM8336AS8-REEL	-40°C~125°C	SOP-8	CBM8336A	Tape and Reel, 4000
CBM8336AMS8	-40°C~125°C	MSOP-8	36M	Tape and Reel, 3000
CBM8336AND8	-40°C~125°C	DFN-8	36N	Tape and Reel, 3000
CBM8339AS14	-40°C~125°C	SOIC-14(SOP14)	CBM8339AS	Tape and Reel, 2500
CBM8339AS14-RL	-40°C~125°C	SOIC-14(SOP14)	CBM8339AS	Tape and Reel, 3000
CBM8339AS14-REEL	-40°C~125°C	SOIC-14(SOP14)	CBM8339AS	Tape and Reel, 4000
CBM8339ATS14	-40°C~125°C	TSSOP-14	CBM8339AT	Tape and Reel, 2500
CBM8339ATS14-RL	-40°C~125°C	TSSOP-14	CBM8339AT	Tape and Reel, 3000
CBM8339ATS14-REEL	-40°C~125°C	TSSOP-14	CBM8339AT	Tape and Reel, 4000