

SCM9602A Ultra-high Voltage Start-up Controller

Features

- Ideal for applications requiring an ultra-wide input voltage range (40V_{DC} to 700V_{DC})
- Low-cost design featuring large starting current in small physical package

Package



Mechanical package: SOT-23
(see "Ordering information" for details).

Applications

- Used for converters with ultra-wide input voltage of 40V_{DC} to 700V_{DC}.

Functional Description

The SCM9602A chip can be used to increase the input voltage range from 40V_{DC} to 5,000V_{DC} when used in combination with our SCM9601A.

Typical Application Circuit

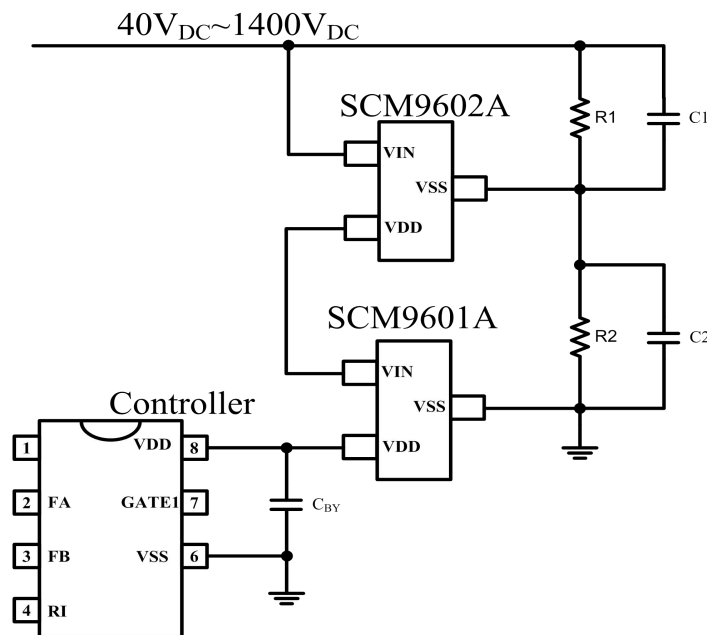

Application shown with an Input Voltage of 40V_{DC} to 1400V_{DC} where SCM9601A and SCM9602A are combined and connected in series

Contents

Features and Package.....	1	Electrical Characteristics.....	3
Application.....	1	Typical Curve.....	3
Functional Description.....	1	Parameter Test Circuit.....	3
Typical Application Circuit.....	1	Application Circuit.....	4
Pins and Descriptions.....	2	Suggestions on Power Supply Use.....	4
Absolute Maximum Ratings.....	2	Ordering ,Package and Tape & Reel Information.....	5
Recommended Operating Conditions.....	2		

Pins

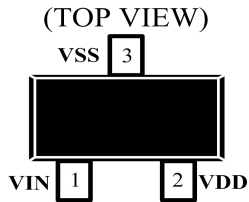

Internal Block Diagram

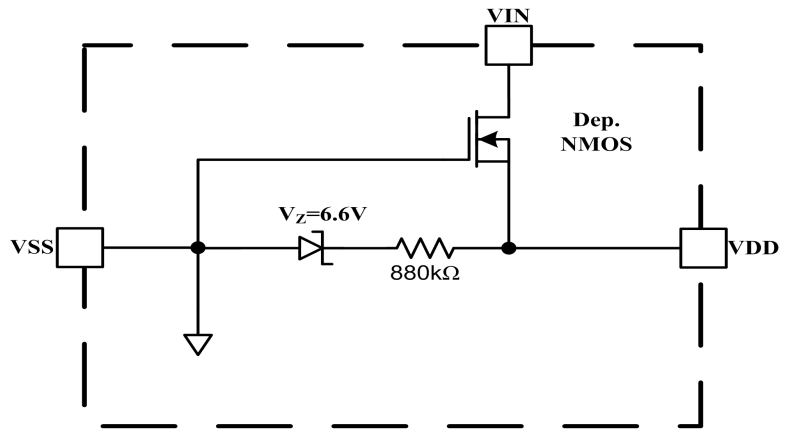

Pin descriptions

Pin No.	Pin name	I/O	Description
1	VIN	P	The high voltage input obtains power from the input voltage and charges the bypass capacitor of the VDD pin to start the controller.
2	VDD	P	Power pin.
3	VSS	P	IC Ground connection

Absolute Maximum Ratings

General test conditions: Free-air, normal operating temperature range (unless otherwise specified).

Parameter	Symbol	Min	Max	Unit
Bias mains voltage	V_{VDD}		40	V
Voltage at the VIN pin	V_{VIN}		700	
Operating junction temperature	T_J	-40	150	°C
Storage temperature	T_{STG}	-40	150	
Lead temperature for soldering (0.6mm from the case within 10s)			260	
Electrostatic Discharge (ESD) rating	Human body model (HBM)		2000	V
	Charging device model (CDM)		1000	

Important: Exposure to Absolute Maximum Rated conditions for an extended period may severely affect the device reliability, and stress levels exceeding the "Absolute Maximum Ratings" may result in permanent damage.

Recommended Operating Conditions

Parameter	Symbol	Min	Max	Unit
Bias mains voltage	V_{VDD}	9	20	V
Operating junction temperature	T_J	-40	125	°C

Electrical Characteristics

General test conditions: Free-air, normal operating temperature range, $V_{SS}=0V$ (unless otherwise specified).

Symbol	Parameter	Test condition	Min	Typ	Max	Unit
V_{BR}	Breakdown voltage of the VIN pin	$V_{VSS} = -8V, I_{VIN} = 10\mu A, V_{VDD} = 0V$	700	-	-	V
V_{TH}	Threshold voltage	$V_{VIN} = 40V, I_{VDD} = 1\mu A$	2	3	4	V
I_{STH}	Maximum starting current	$V_{VIN} = 40V, V_{VDD} = 0V$	1	2	4	mA
I_{DSS}	Leak current of the leakage source	$V_{VSS} = -8V, V_{VIN} = 700V, V_{VDD} = 0V$	-	-	2	μA

Typical Curves

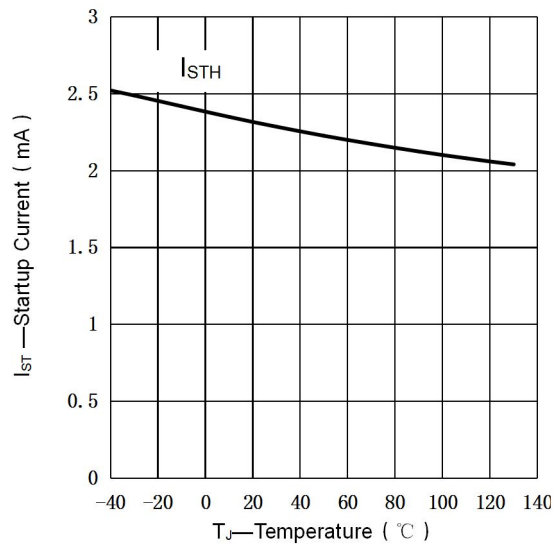

Fig. 1 Starting Current VS Temperature

Parameter Test Circuit

Refer to Fig.2,3,4 and 5 for electrical characteristics related test circuits. The test conditions are normal temperature and closed-loop.

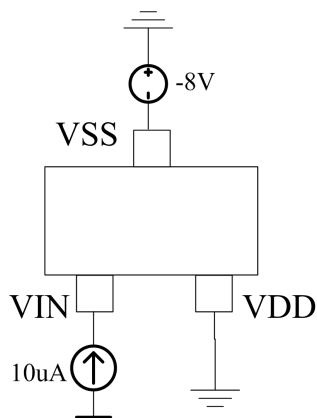

Fig. 2 Leakage Source Breakdown Volt Test Circuit

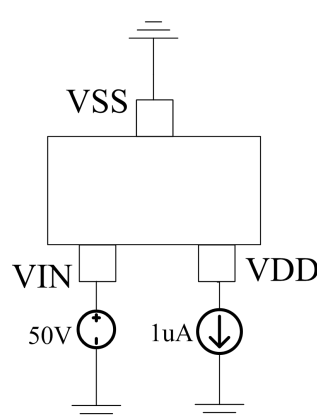

Fig. 3 Value Voltage Test Circuit

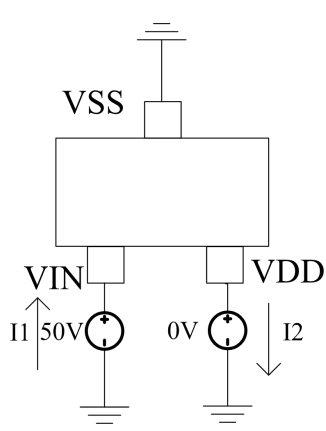

Fig. 4 High Start-up Current Test Circuit

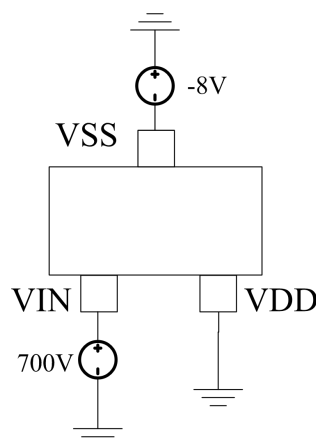

Fig. 5 Leakage Current Test Circuit

Application Circuit

When applying SCM9602A, need to match with our SCM9601A. See Fig. 6 for details. C1 and C2 are high energy storage capacitors at the input end, reducing the fluctuation amplitude of input voltage; R1, R2 is a voltage equalizing resistor which avoids the uneven voltage caused by the difference of leakage current between C1 and C2; D1, D2 and D3 are in rabbits to solve the problem of leakage current difference between C1 and C2.

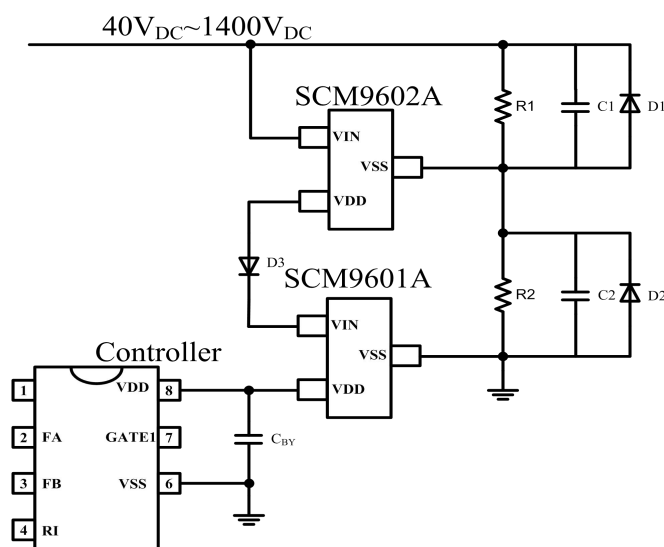

Fig.6 Input $40V_{DS} \sim 1400V_{DS}$ Application Circuit (SCM9601A and SCM9602A in Series)

Suggestions on Power Supply

- 1、SCM9602A can not be used in high voltage start-up circuit alone. In practical use, it is recommended to match our company SCM9601A, which can be used in ultra-high input voltage situations.
- 2、When SCM9601A and SCM9602A are used in series, the leakage current difference between capacitors C1 and C2 should be considered.

Ordering Information

Part number SCM9602ATA	Package SOT-23	Number of pins 3	Product Marking 9602	Tape & Reel 3K/REEL
---------------------------	-------------------	---------------------	-------------------------	------------------------

Product marking and date code

SCM9602XYZ:

(1) SCM9602 = Product designation.

(2) X = Version code information (A-Z).

(3) Y = Packaging definition code; T for SOT package.

(4) Z = Operating temperature range (C = 0°C to +70°C, I = -40°C to +85°C, A = -40°C to +125°C, M = -55°C to +125°C).

Package Information (SOT-23)

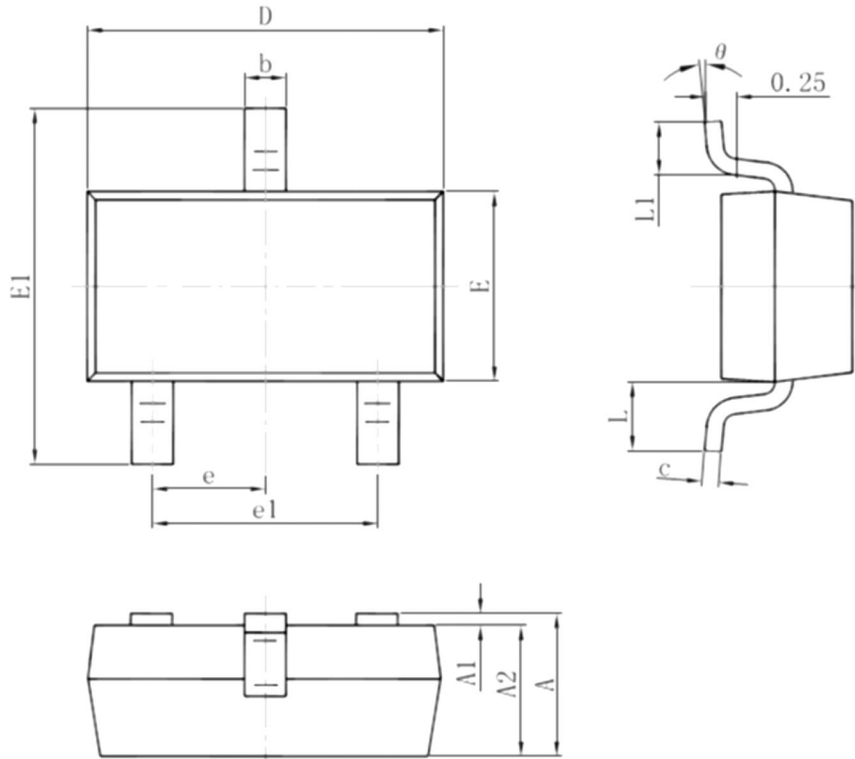

SOT-23				
Mark	Dimensions (mm)		Dimensions (")	
	Minimum	Maximum	Minimum	Maximum
A	0.900	1.150	0.035	0.045
A1	0.000	0.100	0.000	0.004
A2	0.900	1.050	0.035	0.041
b	0.300	0.500	0.012	0.020
c	0.080	0.150	0.003	0.006
D	2.800	3.000	0.110	0.118
E	1.200	1.400	0.047	0.055
E1	2.250	2.550	0.089	0.1
e	0.950 Typical value		0.037 Typical value	
e1	1.800	2.000	0.071	0.079
L	0.550 reference value		0.022 reference value	
L1	0.300	0.500	0.012	0.020
θ	0°	8°	0°	8°

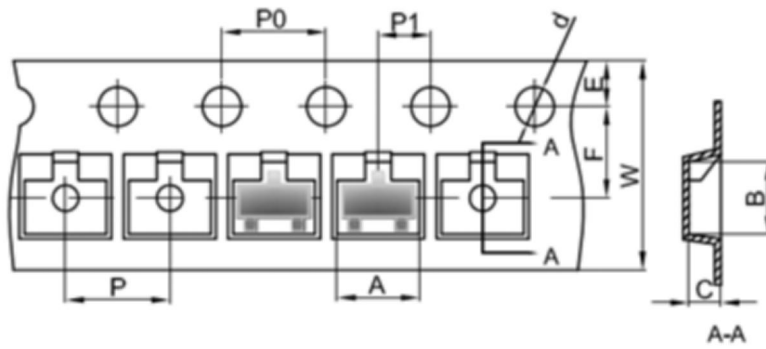

Dimensions (mm)									
Mark	A	B	C	d	E	F	P0	P1	W
SOT-23	3.15	2.77	1.22	Φ1.50	1.75	3.50	4.00	2.00	8.00
Tolerance	+/-0.1	+/-0.1	+/-0.1	+/-0.1	+/-0.1	+/-0.1	+/-0.1	+/-0.1	+0.3/-0.1

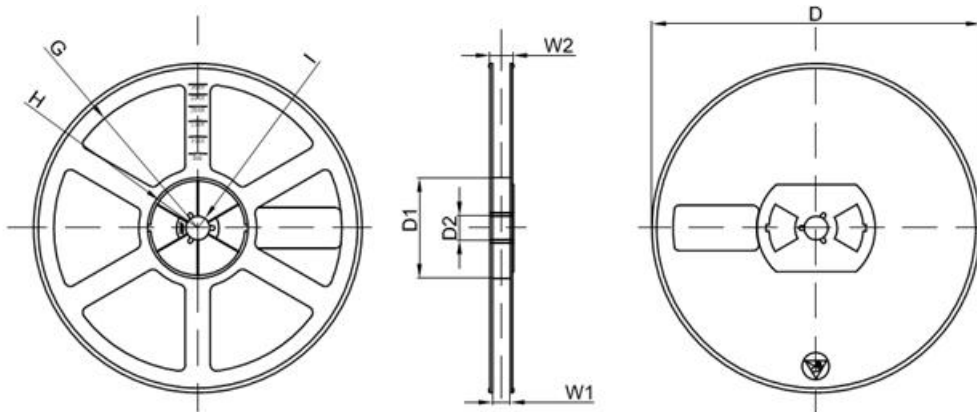
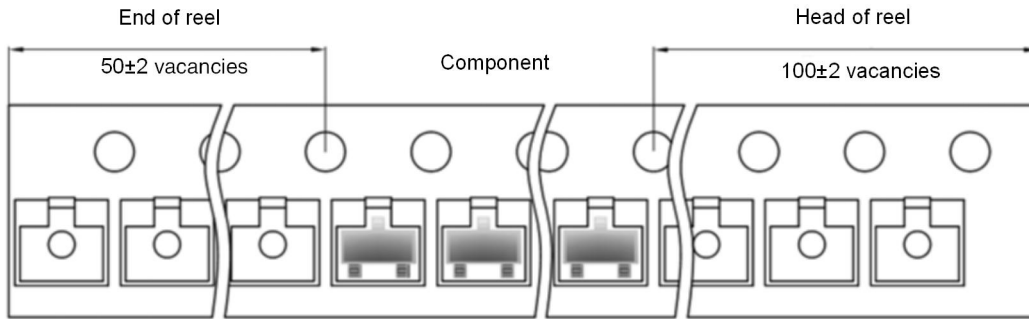

Dimensions (mm)								
Mark	D	D1	D2	G	H	I	W1	W2
7" reel	Φ178.00	54.40	13.00	78.00 (radius)	25.60 (radius)	6.50 (radius)	9.50	12.30
Tolerance	+/-2	+/-1	+/-1	+/-1	+/-1	+/-1	+/-1	+/-1

On reel	Reel dimensions	In carton	Carton dimensions (mm)	In plate box	Plate box dimensions (mm)
3000PCS	7"	45,000PCS	203*203*195	180,000PCS	438*438*220

Mornsun Guangzhou Science & Technology Co., Ltd.

Address: No. 5, Kehui St. 1, Kehui Development Center, Science Ave., Guangzhou Science City, Luogang District, Guangzhou, P. R. China

Tel: 86-20-38601850

Fax: 86-20-38601272

E-mail: sales@mornsun.cn